



# MATRIX HIGH SCHOOL

## Paper, Answer and Solution

### NATIONAL STANDARD EXAMINATION IN JUNIOR SCIENCE (NSEJS) 2019-20

**Instructions to Candidates — Read carefully and strictly follow each of them**

1. Question paper code is given on top right corner of each page of question paper. It must be mentioned in YOUR OMR sheet (in the space provided). Otherwise your answer sheet (OMR sheet) will NOT be assessed.
2. Use and carrying calculators of any type is strictly prohibited.
3. Use and even carrying smart watches, phones, i-pads or any other communication devices or any other objectionable material in examination centre is strictly prohibited.
4. On the answer sheet, make all the entries correctly, carefully in the space(s) provided, in capital letters as well as by properly darkening the appropriate bubbles using blue or black ball point pen only. Incomplete/ incorrect/ carelessly filled information may disqualify your candidature. Please take care while entering.
5. Please do not make any mark other than filling the appropriate bubbles properly in the space provided on the answer sheet. Further, do not write on the back side of the answer sheet.
6. As answer sheets are evaluated using machine, change of entry is not allowed. Even scratching or overwriting may result in a wrong score.
7. Question paper has 80 multiple choice questions. Each question has four alternatives, out of which only one is correct. Choose the correct alternative and fill the appropriate bubble, as shown:  
  
Q. (a)  (b)  (c)  (d)
8. Correct answer carries 3 marks, wrong answer –1 mark (negative 1), no attempt – zero marks.
9. Rough work should be done in the space provided in the question paper only.
10. Candidates are not permitted to leave the examination hall before the completion of the examination schedule (i.e. before 12:00 hrs).
11. Your answer sheet consists of two pages original copy and candidate's copy. Do not detach them till the end of the examination. At the end of examination, submit your answer paper (original copy) to the invigilator and take away the student's copy for your further reference.

**ONLY ONE OUT OF FOUR OPTIONS IS CORRECT**

1. Apples dropping from apple trees were observed by many people before Newton. But why they fall, was explained by Isaac Newton postulating the law of universal gravitation. Which of the following statements best describes the situation?

- (a) The force of gravity acts only on the apple
- (b) The apple is attracted towards the surface of the earth
- (c) Both earth and apple experience the same force of attraction towards each other
- (d) Apple falls due to earth's gravity and hence only (a) is true and (c) is absurd

**Answer (c)**

**Sol.** According to Newton's law of gravitation, force of gravitation acts on both interacting object having same magnitude of force and this force is attractive in nature.

2. A rectangular metal plate, shown in the adjacent figure has a charge of  $420 \mu\text{C}$  assumed to be uniformly distributed over it. Then how much is the charge over the shaded area? No part of metal plate is cut. (Circles and the diagonal are shown for clarity only.  $\pi = 22/7$ )

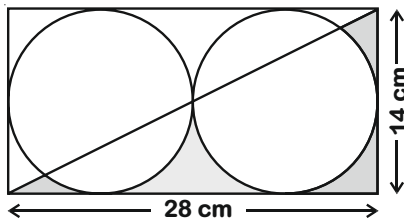

- (a)  $45 \mu\text{C}$
- (b)  $450 \mu\text{C}$
- (c)  $15 \mu\text{C}$
- (d)  $150 \mu\text{C}$

**Answer (a)**

**Sol.** Charge per unit area =  $\frac{Q}{A}$

$$\begin{aligned} \text{Area of shaded portion} &= \frac{1}{2} \left[ 28 \times 14 - 2 \times \frac{22}{7} \times 7^2 \right] \\ &= 42 \text{ cm}^2 \end{aligned}$$

$$\begin{aligned} \text{Charge on shaded portion} &= \frac{420}{28 \times 14} \times 42 \\ &= 45 \mu\text{C} \end{aligned}$$

3. In the adjacent circuit, the voltages across AD, BD and CD are 2 V, 6 V and 8 V respectively. If resistance  $R_A = 1 \text{ k}\Omega$ , then the values of resistances  $R_B$  and  $R_C$  are \_\_\_\_\_ and \_\_\_\_\_ respectively.

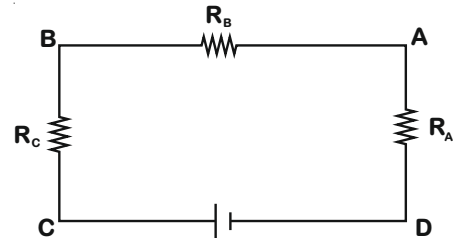

- (a)  $4 \text{ k}\Omega$  and  $6 \text{ k}\Omega$
- (b)  $2 \text{ k}\Omega$  and  $1 \text{ k}\Omega$
- (c)  $1 \text{ k}\Omega$  and  $2 \text{ k}\Omega$
- (d) Data insufficient as battery voltages is not given

**Answer (b)**

**Sol.** Current flowing through circuit =  $\frac{2\text{V}}{1 \times 10^3 \Omega} = 2 \times 10^{-3} \text{ A}$

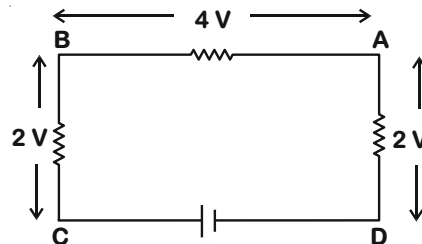

$$R_B = \frac{4}{2 \times 10^{-3}} = 2 \text{ k}\Omega$$

$$R_C = \frac{2}{2 \times 10^{-3}} = 1 \text{ k}\Omega$$

4. A new linear scale of temperature measurement is to be designed. It is called a 'Z scale' on which the freezing and boiling points of water are 20 Z and 220 Z respectively. What will be the temperature shown on the 'Z scale' corresponding to a temperature of  $20^\circ\text{C}$  on the Celsius scale?

- (a) 10 Z
- (b) 20 Z
- (c) 40 Z
- (d) 60 Z

**Answer (d)**

**Sol.**  $\frac{T - 20}{220 - 20} = \frac{20 - 0}{100}$   
 $\Rightarrow T = 60 \text{ Z}$

5. Some waveforms among I, II, III and IV superpose (add graphically) to produce the waveforms P, Q, R and S. Among the following, match the pairs that give the correct combinations:

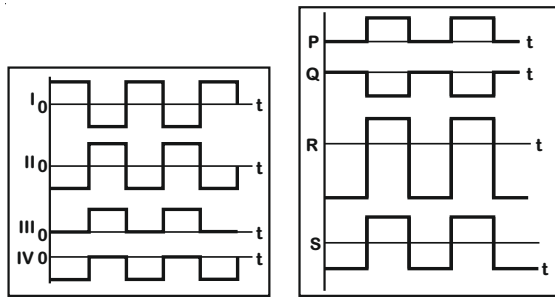

Resultant	Superposition of
P	(K) III and IV
Q	(L) II and IV
R	(M) I, II and III
S	(N) I and IV
	(O) II and III

- (a) P ↔ O, Q ↔ N, R ↔ L, S ↔ M  
 (b) P ↔ M, Q ↔ N, R ↔ L, S ↔ K  
 (c) P ↔ M, Q ↔ N, R ↔ K, S ↔ L  
 (d) P ↔ O, Q ↔ M, R ↔ L, S ↔ K

Answer (b)

Sol. III + IV

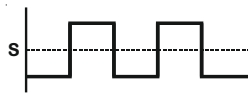

II + IV

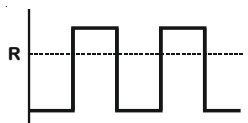

I + II + III



II + III

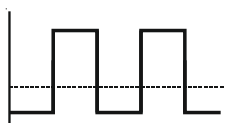

I + IV



6. A rigid body of mass  $m$  is suspended from point O using an inextensible string of length  $L$ . When it is displaced through an angle  $\theta$ , what is the change in the potential energy of the mass? (Refer adjacent figure.)

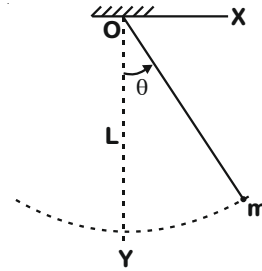

- (a)  $mgL(1 - \cos\theta)$       (b)  $mgL(\cos\theta - 1)$   
 (c)  $mgL\cos\theta$       (d)  $mgL(1 - \sin\theta)$

Answer (a)

Sol.

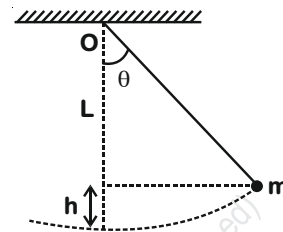

$$h = L - L\cos\theta$$

$$\text{So } \Delta PE = mgh = mg(L - L\cos\theta) = mgL(1 - \cos\theta)$$

7. A piece of wire P and three identical cells are connected in series. An amount of heat is generated in a certain time interval in the wire due to passage of current. Now the circuit is modified by replacing P with another wire Q and N identical cells, all connected in series. Q is four times longer in length than P. The wire P and Q are of same material and have the same diameter. If the heat generated in second situation is also same as before in the same time interval, then find N.

- (a) 4      (b) 6  
 (c) 16      (d) 36

Answer (b)

$$\text{Sol. } R_P = \frac{\rho l}{A}$$

$$R_Q = \frac{4\rho l}{A}$$

$$H_1 = \frac{(3V)^2}{\frac{\rho l}{A}} t$$

$$H_2 = \frac{(nV)^2}{\frac{4\rho l}{A}} t$$

$$H_1 = H_2$$

$$\Rightarrow n = 6$$

8.

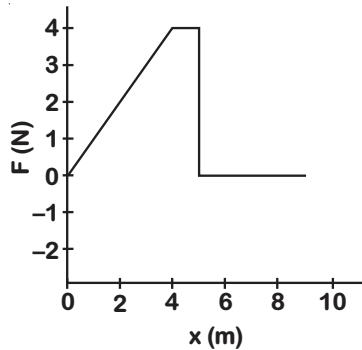

Refer to the adjacent figure. A variable force  $F$  is applied to a body of mass 6 kg at rest. The body moves along  $x$ -axis as shown. The speed of the body at  $x = 5$  m and  $x = 6$  m is \_\_\_ and \_\_\_ respectively.

- (a) 0 m/s, 0 m/s  
 (b) 0 m/s, 2 m/s  
 (c) 2 m/s, 2 m/s  
 (d) 2 m/s, 4 m/s

Answer (c)

Sol.  $\therefore W = F \times x$

For  $x = 0$  to  $x = 5$

$$W = \frac{1}{2} \times (4) \times (5+1)$$

$$W = 12 \text{ J}$$

From work-energy theorem

$$W = \Delta KE$$

$$v = 2 \text{ m/s}$$

From  $x = 5$  m to  $x = 6$  m

$$\therefore F = 0$$

$$\therefore v = \text{constant} = 2 \text{ m/s}$$

9. Consider the motion of a small spherical steel body of mass  $m$ , falling freely through a long column of a fluid that opposes its motion with a force proportional to its speed. Initially the body moves down fast, but after some time attains a constant velocity known as terminal velocity. If weight  $mg$ , opposing force ( $F_v$ ) and buoyant force ( $F_b$ ) act on the body, then the correct equation relating these forces, after the terminal velocity is reached, is:

- (a)  $mg + F_v = F_b$   
 (b)  $mg = F_v - F_b$   
 (c)  $mg = F_v + F_b$   
 (d) None

Answer (c)

Sol. After the terminal velocity reached



$$F_{\text{net}} = 0$$

$$mg - F_v - F_b = 0$$

$$mg = F_v + F_b$$

10. At any instant of time, the total energy ( $E$ ) of a simple pendulum is equal to the sum of its kinetic energy  $\left(\frac{1}{2}mv^2\right)$  and potential energy  $\left(\frac{1}{2}kx^2\right)$ , where,  $m$  is the mass,  $v$  is the velocity,  $x$  is the displacement of the bob and  $k$  is a constant for the pendulum. The amplitude of oscillation of the pendulum is 10 cm and its total energy is 4 mJ. Find  $k$ .
- (a)  $1.8 \text{ Nm}^{-1}$   
 (b)  $0.8 \text{ Nm}^{-1}$   
 (c)  $0.5 \text{ Nm}^{-1}$   
 (d) Data insufficient

Answer (b)

Sol.  $\therefore$  Potential energy  $PE = \frac{1}{2}kx^2$

At maximum height, potential energy = Total energy

$$4 \times 10^{-3} = \frac{1}{2} \times k \times (0.1)^2$$

$$k = \frac{4 \times 10^{-3} \times 2}{(0.1)^2}$$

$$k = 0.8 \text{ Nm}^{-1}$$

11. When a charged particle with charge  $q$  and mass  $m$  enters uniform magnetic field  $B$  with velocity  $v$  at right angles to  $B$ , the force on the moving particle is given by  $qvB$ . This force acts as the centripetal force making the charged particle go in a uniform circular motion with radius  $r = \frac{mv}{Bq}$ . Now if a hydrogen ion and a deuterium ion enter the magnetic field with velocities in the ratio 2:1 respectively, then the ratio of their radii will be \_\_\_\_\_.

- (a) 1 : 2  
 (b) 2 : 1  
 (c) 1 : 4  
 (d) 1 : 1

Answer (d)

Sol.  $\therefore r = \frac{mv}{Bq}$

Hydrogen ion  $\rightarrow {}_1\text{H}^1$

Deuterium ion  $\rightarrow {}_1\text{H}^2$

$$\frac{r_p}{r_d} = \frac{m_p v_p}{Bq_p} \times \frac{Bq_d}{m_d v_d}$$

$$\frac{r_p}{r_d} = \frac{m_p}{m_d} \times \frac{v_p}{v_d} \times \frac{q_d}{q_p}$$

$$\frac{r_p}{r_d} = \frac{1}{2} \times \frac{2}{1} \times \frac{1}{1} = \frac{1}{1}$$

$$r_p : r_d = 1 : 1$$

12. In a screw-nut assembly (shown below) the nut is held fixed in its position and the screw is allowed to rotate inside it. A convex lens (L) of focal length 6.0 cm is fixed on the nut. An object pin (P) is attached to the screw head. The image of the object is observed on a screen Y. When the screw head is rotated through one rotation, the linear distance moved by the screw tip is 1.0 mm. The observations are made only when the image is obtained in the same orientation on the screen. At a certain position of P, the image formed is three times magnified as that of the pin height. Through how many turns should the screw head be rotated so that the image is two times magnified?

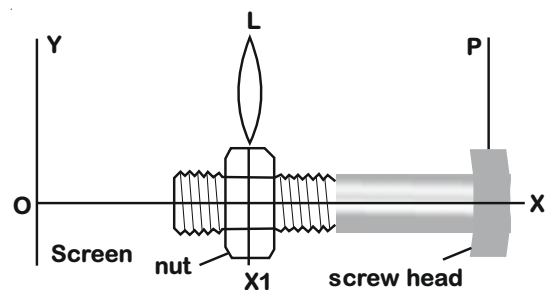

- (a) 8
- (b) 10
- (c) 12
- (d) 14

Answer (b)

Sol.  $m = \frac{f}{f+u}$

$$\Rightarrow -3 = \frac{6}{6+4} \text{ (first condition)}$$

$$\Rightarrow u = -8 \text{ cm}$$

$$-2 = \frac{6}{6+(u-x)} \text{ (second condition)}$$

$$\Rightarrow -2 = \frac{6}{6+(-8-x)}$$

$$\Rightarrow x = 1 \text{ cm}$$

$$\text{Number of turns} = \frac{1}{0.1} = 10$$

13. The triangular face of a crown glass prism ABC is isosceles. Length AB = length AC and the rectangular face with edge AC is silvered. A ray of light is incident normally on rectangular face with edge AB. It undergoes reflections at AC and AB internally and it emerges normally through the rectangular base with edge BC. Then angle BAC of the prism is \_\_\_\_\_.
- (a) 24°
  - (b) 30°
  - (c) 36°
  - (d) 42°

Answer (c)

Sol. When we tracing the path of light ray, we get

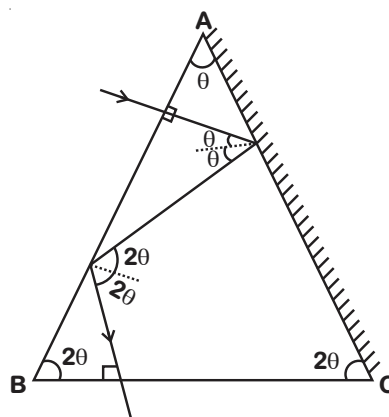

$$\therefore \theta + 2\theta + 2\theta = 180^\circ$$

$$5\theta = 180^\circ$$

$$\theta = \frac{180^\circ}{5}$$

$$\theta = 36^\circ$$

14. A Physics teacher and his family are travelling in a car on a highway during a severe lightning storm. Choose the correct option:

- (a) Safest place will be inside the car as the charges due to lightning tend to remain on the metal sheet / skin of the vehicle if struck by lightning.
- (b) It's too dangerous to be inside the car. As the car has a metal body the charges tend to accumulate on the surface and will generate a strong electric field inside the car.
- (c) Safest place is under a tree. It's better to get drenched under a tree as the wet tree will provide a path to the charges for earthing.
- (d) It is safer to exit the car and stand on open ground

Answer (a)

Sol. By the concept of electrostatic shielding

15. A conductor in the form of a circular loop is carrying current  $I$ . The direction of the current is as shown. Then which figure represents the correct direction of magnetic field lines on the surfaces of the planes XY and XZ. (Consider those surfaces of the XY and XZ planes which are seen in the figure.)

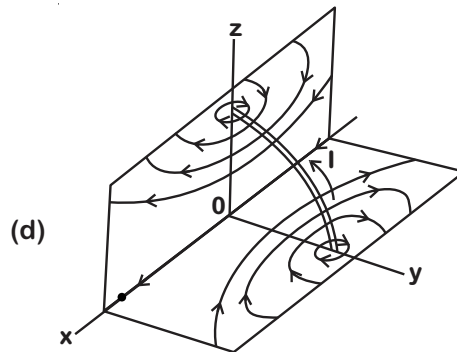
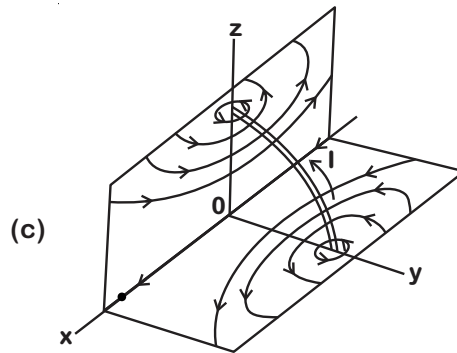
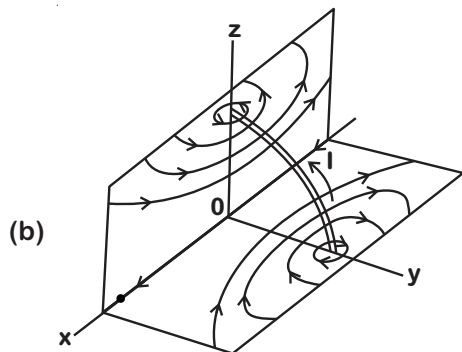
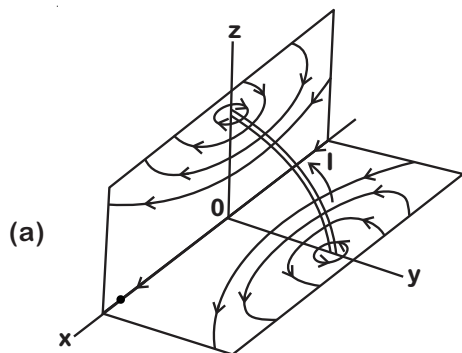

Answer (a)

16. A school is located between two cliffs. When the metal bell is struck by school attendant, first echo is heard by him after 2.4 s and second echo follows after 2.0 s for him at the same position near the bell. If the velocity of sound in air is  $340 \text{ ms}^{-1}$  at the temperature of the surroundings, then the distance between the cliffs is approximately \_\_\_\_.

- (a) 0.488 km
- (b) 0.751 km
- (c) 1.16 km
- (d) 1.41 km

Answer (c)

Sol.  $\therefore v = \frac{2d}{t}$

$$d_1 = \frac{v \times t_1}{2} = \frac{340 \times 2.4}{2} = 408 \text{ m}$$

$$d_2 = \frac{v \times t_2}{2} = \frac{340 \times (2.4 + 2)}{2} = 748$$

$$d = d_1 + d_2 = 408 + 748$$

$$d = 1156 \text{ m}$$

$$d \approx 1.16 \text{ km}$$

17. The radius of curvature of a convex mirror is 'x'. The distance of an object from focus of this mirror is 'y'. Then what is the distance of image from the focus?

- (a)  $\frac{y^2}{4x}$                       (b)  $\frac{x^2}{y}$   
 (c)  $\frac{x^2}{4y}$                       (d)  $\frac{4y^2}{x}$

Answer (c)

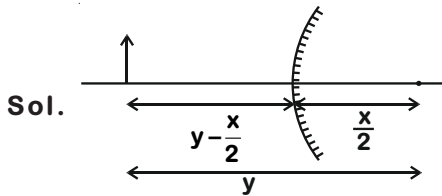

$$\frac{1}{f} = \frac{1}{v} + \frac{1}{u}$$

$$\frac{2}{x} = \frac{1}{v} - \frac{2}{2y-x}$$

$$\Rightarrow \frac{1}{v} = \frac{2}{x} + \frac{2}{2y-x}$$

$$\Rightarrow v = \frac{x(2y-x)}{4y}$$

Distance between image and focus

$$= \frac{x}{2} - \frac{x(2y-x)}{4y}$$

$$= \frac{x^2}{4y}$$

18. A piece of ice is floating in water at 4°C in a beaker. When the ice melts completely, the water level in the beaker will

- (a) Rise  
 (b) Fall  
 (c) Remains unchanged  
 (d) Unpredictable

Answer (a)

Sol. Immersed Volume  $V_i = \frac{\rho_{\text{ice}}}{\rho_{w4^\circ\text{C}}} V_{\text{total}}$

After melting  $V_{\text{formed}} = \frac{m_{\text{ice}}}{(\rho_w)_{0^\circ\text{C}}} = \frac{\rho_{\text{ice}} V_{\text{total}}}{(\rho_w)_{0^\circ\text{C}}}$

$V_{\text{formed}} > V_i$  (As  $\rho_{4^\circ\text{C}} > \rho_{0^\circ\text{C}}$ )

∴ Level should increase

19. A particle experiences constant acceleration for 20 s after starting from rest. If it travels a distance  $S_1$  in the first 10 s and distance  $S_2$  in the next 10 s, the relation between  $S_1$  and  $S_2$  is:

- (a)  $S_2 = 3S_1$                       (b)  $S_1 = 3S_2$   
 (c)  $S_2 = 2S_1$                       (d)  $S_1 = 10S_2$

Answer (a)

Sol.  $S_1 = \frac{1}{2} a \times t^2$

$$= \frac{1}{2} \times a \times 10^2$$

$$= 50a$$

$$v_1 = u + at$$

$$= 10a$$

$$S_2 = v_1 t + \frac{1}{2} a t^2$$

$$= 150a$$

$$S_2 = 3S_1$$

20. A sound wave is produced by a vibrating metallic string stretched between its ends. Four statements are given below. Some of them are correct.

- (P) Sound wave is produced inside the string  
 (Q) Sound wave in the string is transverse  
 (R) Wavelength of the sound wave in surrounding air is equal to the wavelength of the transverse wave on the string  
 (S) Loudness of sound is proportional to the square of the amplitude of the vibrating string

Choose the correct option.

- (a) P                                      (b) R and S  
 (c) P and Q                              (d) S

Answer (d)

Sol. ∴ Loudness  $\propto$  (Amplitude)<sup>2</sup>

21. How many positive integers N give a remainder 8 when 2008 is divided by N?

- (a) 12  
 (b) 13  
 (c) 14  
 (d) 15

Answer (d)

**Sol.** Here, remainder is 8

∴ N must be greater than 8

$$N \text{ must be factors of } = 2008 - 8 = 2000 \\ = 2^4 \times 5^3$$

$$\text{Total number of factors} = 5 \times 4 = 20$$

∴ Factors greater than 8 are 10, 16, 20, 25, 40, 50, 80, 100, 125, 200, 250, 400, 500, 1000, 2000.

So, total number of solutions = 15

Hence, option (d) is correct

22. What is the product of all the roots of the equation  $\sqrt{5|x|+8} = \sqrt{x^2-16}$ ?

- (a) -64                      (b) -24  
(c) 576                      (d) 24

**Answer (a)**

**Sol.**  $\sqrt{5|x|+8} = \sqrt{x^2-16}$

On squaring,

$$\Rightarrow 5|x| + 8 = x^2 - 16$$

$$\Rightarrow x^2 - 5|x| - 24 = 0$$

$$\Rightarrow (|x| - 8)(|x| + 3) = 0$$

$$\Rightarrow |x| = 8 \qquad |x| = -3$$

$$x = \pm 8$$



$$\text{Product of roots} = (+8) \times (-8) = -64$$

Option (a) is correct.

23. LCM of two numbers is 5775. Which of the following cannot be their HCF?

- (a) 175                      (b) 231  
(c) 385                      (d) 455

**Answer (d)**

**Sol.**  $5775 = 3 \times 5 \times 5 \times 7 \times 11$

$$175 = 5 \times 5 \times 7$$

$$231 = 7 \times 3 \times 11$$

$$385 = 7 \times 5 \times 11$$

$$455 = 13 \times 7 \times 5$$

Hence, 455 cannot be HCF.

24. Let  $\alpha$  and  $\beta$  be the roots of  $x^2 - 5x + 3 = 0$  with  $\alpha > \beta$ . If  $a_n = \alpha^n - \beta^n$  for  $n \geq 1$  then the value of

$$\frac{3a_6 + a_8}{a_7} \text{ is}$$

- (a) 2                      (b) 3  
(c) 4                      (d) 5

**Answer (d)**

**Sol.**  $\frac{3a_6 + a_8}{a_7} = \frac{3(\alpha^6 - \beta^6) + (\alpha^8 - \beta^8)}{\alpha^7 - \beta^7}$

$$= \frac{\alpha^6[\alpha^2 + 3] - \beta^6[\beta^2 + 3]}{\alpha^7 - \beta^7}$$

$$= \frac{5(\alpha^7 - \beta^7)}{(\alpha^7 - \beta^7)} = 5 \quad \left[ \begin{array}{l} \because \alpha^2 + 3 = 5\alpha \text{ and} \\ \beta^2 + 3 = 5\beta \end{array} \right]$$

25. The number of triples (x, y, z) such that any one of these numbers is added to the product of the other two, the result is 2, is

- (a) 1  
(b) 2  
(c) 4  
(d) Infinitely many

**Answer (b)**

**Sol.**  $x + yz = 2$                       ... (i)

$$y + zx = 2 \qquad \dots \text{(ii)}$$

$$z + xy = 2 \qquad \dots \text{(iii)}$$

Subtracting (ii) from (i),

$$(x - y) = z(x - y)$$

∴ Either  $x = y$  or  $z = 1$

**Case I :**

If  $z = 1$

$$\Rightarrow x + y = 2 \text{ and } xy = 1$$

$$\therefore x + \frac{1}{x} = 2$$

$$\Rightarrow x^2 - 2x + 1 = 0$$

$$\Rightarrow x = 1$$

$$\therefore y = 1$$

∴ (1, 1, 1) is one of the triplet

**Case II :**

If  $x = y$

$$\Rightarrow x(1 + z) = 2 \text{ and } z + x^2 = 2$$

$$\Rightarrow x + zx = z + x^2$$

$$\Rightarrow x - z = x(x - z)$$

⇒ Either  $x = z$  or  $x = 1$

(i) If  $x = z \Rightarrow x = y = z$

$$\Rightarrow x + x^2 = 2$$

$$\Rightarrow x = 1 \text{ or } -2$$

∴ (-2, -2, -2) is second triplet



(ii) If  $x = 1 \Rightarrow y = 1$

$$\therefore z = 1$$

$\therefore (1, 1, 1)$  is repeated triplet.

So only two triplets  $(1, 1, 1)$  and  $(-2, -2, -2)$  are possible.

Hence, option (b) is correct.

26. In rectangle ABCD, AB = 5 and BC = 3. Points F and G are on the line segment CD so that DF = 1 and GC = 2. Lines AF and BG intersect at E. What is the area of AEB?

- (a) 10 sq. units
- (b)  $15/2$  sq. units
- (c)  $25/2$  sq. units
- (d) 20 sq. units

Answer (c)

Sol.

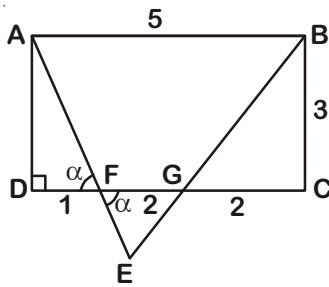

$$\text{Area of (AFGB)} = \frac{1}{2}(2+5) \times 3 = 10.5$$

$$\left[ \begin{array}{l} \because CD = CG + GF + FD \\ 5 = 2 + GF + 1 \\ \therefore GF = 5 - 3 = 2 \end{array} \right]$$

Now  $\triangle EFG \sim \triangle EAB$

$$\Rightarrow \frac{\text{ar}(\triangle AEB)}{\text{ar}(\triangle EFG)} = \frac{25}{4}$$

$$\therefore \frac{\text{ar}(\triangle EFG)}{\text{ar}(\triangle AEB)} = \frac{4}{25}$$

$$\Rightarrow 1 - \frac{\text{ar}(\triangle EFG)}{\text{ar}(\triangle AEB)} = 1 - \frac{4}{25}$$

$$\Rightarrow \frac{\text{ar}(\text{AFGB})}{\text{ar}(\triangle AEB)} = \frac{21}{25}$$

$$\Rightarrow \text{ar}(\triangle AEB) = \frac{10.5 \times 25}{21} = 12.5 = \frac{25}{2} \text{ sq. units}$$

Hence, option (c) is correct.

27. In the given figure, two concentric circles are shown with centre O. PQRS is a square inscribed in the outer circle. It also circumscribes the inner circle, touching it at points B, C, D and A. What is the ratio of the perimeter of the outer circle to that of quadrilateral ABCD?

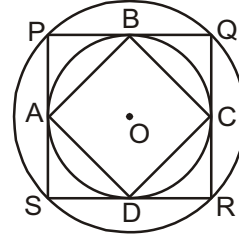

- (a)  $\frac{\pi}{4}$
- (b)  $\frac{3\pi}{2}$
- (c)  $\frac{\pi}{2}$
- (d)  $\pi$

Answer (c)

Sol.

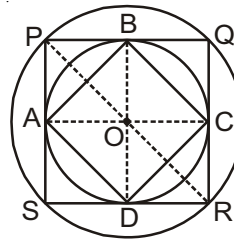

Let radius of outer circle be  $r$ .

$$\therefore PR = 2r$$

$$\text{and } PQ = \sqrt{2}r$$

$$\text{Radius of inner circle} = OA = \frac{PQ}{2} = \frac{r}{\sqrt{2}}$$

$$AB = \sqrt{OA^2 + OB^2} = \sqrt{\frac{r^2}{2} + \frac{r^2}{2}} = r$$

$$\therefore \frac{\text{Circumference of outer circle}}{\text{Perimeter of ABCD}} = \frac{2\pi r}{4 \times r} = \frac{\pi}{2}$$

Option (c) is correct.

28. If  $a, b, c$  are distinct real numbers such that

$$a + \frac{1}{b} = b + \frac{1}{c} = c + \frac{1}{a} \text{ evaluate } abc.$$

- (a)  $\pm\sqrt{2}$
- (b)  $\sqrt{2} - 1$
- (c)  $\sqrt{3}$
- (d)  $\pm 1$

Answer (d)

Sol.  $a + \frac{1}{b} = b + \frac{1}{c} = c + \frac{1}{a}$

$$\Rightarrow a - b = \frac{1}{c} - \frac{1}{b}$$

$$a - b = \frac{b - c}{bc}$$

$$bc = \frac{b - c}{a - b} \quad \dots(i)$$

$$\Rightarrow b + \frac{1}{c} = c + \frac{1}{a}$$

$$b - c = \frac{c - a}{ac}$$

$$ac = \frac{c - a}{b - c} \quad \dots(ii)$$

$$\Rightarrow a + \frac{1}{b} = c + \frac{1}{a}$$

$$a - c = \frac{1}{a} - \frac{1}{b} = \frac{b - a}{ab}$$

$$ab = \frac{b - a}{a - c} \quad \dots(iii)$$

From (i), (ii) & (iii), we get

$$(ab)(ac)(bc) = \frac{b - c}{a - b} \times \frac{c - a}{b - c} \times \frac{b - a}{a - c}$$

$$a^2 b^2 c^2 = 1$$

$$abc = \pm 1$$

$\therefore$  Option (d) is correct.

29. If the equation  $(\alpha^2 - 5\alpha + 6)x^2 + (\alpha^2 - 3\alpha + 2)x + (\alpha^2 - 4) = 0$  has more than two roots, then the value of  $\alpha$  is

(a) 2

(b) 3

(c) 1

(d) None of these

**Answer (a)**

Sol. If  $(\alpha^2 - 5\alpha + 6)x^2 + (\alpha^2 - 3\alpha + 2)x + (\alpha^2 - 4) = 0$  has more than two roots, then this equation is an identity.

$$\Rightarrow \alpha^2 - 5\alpha + 6 = 0, \alpha^2 - 3\alpha + 2 = 0 \text{ and } \alpha^2 = 4$$

$$\Rightarrow \alpha = 2, 3 \text{ and } \alpha = 1, 2 \text{ and } \alpha = -2, 2$$

$\therefore$  Common value of  $\alpha$  is 2.

Option (a) is correct.

30. Mr. X with his eight children of different ages is on a family trip. His oldest child, who is 9 years old saw a license plate with a 4-digit number in which each of two digits appear two times. "Look daddy!" she exclaims. "That number is evenly divisible by the age of each of us kids!". "That's right," replies Mr. X, "and the last two digits just happen to be my age". Which of the following is not the age of one of Mr. X's children?

(a) 4

(b) 5

(c) 6

(d) 7

**Answer (b)**

Sol. Possible ages of children can be 1, 2, 3, 4, 5, 6, 7, 8, 9.

$\therefore$  There are 8 children and oldest child is 9 years old.

$\therefore$  Sum of four digits must be divisible by 9.

If four digit number is divisible by 9 then possible combinations of digits must be (0, 9), (1, 8), (2, 7), (3, 6), (4, 5)

Also the number should be even because if number is not divisible by 2 then it cannot be divisible by 4 and 8.

Hence age of the child cannot be 5

$\therefore$  Even number is not divisible by 5 if last digit is non-zero.

If last digit is zero then only two possibilities can occur.

99 $\square$ 00 is not possible because last two digits are the age of his father.

99 $\square$ 90 is not divisible by 4 and 8 both hence it is also not possible.

$\therefore$  Option (b) is correct.

31. How many number lie between 11 and 1111 which divided by 9 leave a remainder 6 and when divided by 21 leave a remainder 12?

(a) 18

(b) 28

(c) 8

(d) None of these

**Answer (a)**

Sol. Numbers which are divided by 9 leave a remainder 6 are 24, 33, 42, 51, ..., 1104 ... (i)

Numbers which are divided by 21 leaves a remainder 12 are 33, 54, ..., 1104 ... (ii)

$\therefore$  Total numbers are the common number of terms of sequence (i) and (ii).

Now let there are 'n' common terms of (i) and (ii) have a common difference of 63 starting from number 33 ( $\because$  L.C.M. of 9 and 21 is 63)

$$\therefore 33 + (n-1) \times 63 = 1104$$

$$\Rightarrow \boxed{n=18}$$

$\therefore$  Option (a) is correct.

32. Two unbiased dice are rolled. What is the probability of getting a sum which is neither 7 nor 11?

- (a)  $\frac{7}{9}$  (b)  $\frac{7}{18}$   
 (c)  $\frac{2}{9}$  (d)  $\frac{11}{18}$

**Answer (a)**

**Sol.** Total number of outcomes =  $6 \times 6 = 36$

Outcomes whose sum is either 7 or 11 = (1, 6) (2, 5), (3, 4), (4, 3), (5, 2), (6,1), (5, 6), (6, 5)

Number of outcomes whose sum is neither 7 nor 11 =  $36 - 8 = 28$

$$\therefore \text{Required probability} = \frac{28}{36} = \frac{7}{9}$$

Hence, option (a) is correct.

33. The solution of the equation  $1 + 4 + 7 + \dots + x = 925$  is

- (a) 73 (b) 76  
 (c) 70 (d) 74

**Answer (a)**

**Sol.** Let x be the  $n^{\text{th}}$  term.

$$\therefore x = 1 + (n-1) \times 3$$

$$\Rightarrow x = 1 + 3n - 3$$

$$\Rightarrow x = (3n - 2)$$

$$\therefore S_n = 925 = \frac{n}{2}(1 + (3n - 2))$$

$$\Rightarrow 925 = \frac{n}{2}(3n - 1)$$

$$\Rightarrow 1850 = 3n^2 - n$$

$$\Rightarrow 3n^2 - n - 1850 = 0$$

$$\Rightarrow 3n^2 - 75n + 74n - 1850 = 0$$

$$\Rightarrow 3n(n - 25) + 74(n - 25) = 0$$

$$\Rightarrow (n - 25)(3n + 74) = 0$$

$$\Rightarrow n = 25 \quad \left[ \because n \neq \frac{-74}{3} \right]$$

$$\therefore x = 3 \times 25 - 2 = 73$$

Hence, option (a) is correct.

34. An observer standing at the top of a tower, finds that the angle of elevation of a red bulb on the top of a light house of height H is  $\alpha$ . Further, he finds that the angle of depression of reflection of the bulb in the ocean is  $\beta$ . Therefore, the height of the tower is

- (a)  $\frac{H(\tan\beta - \tan\alpha)}{(\tan\beta + \tan\alpha)}$   
 (b)  $\frac{H\sin(\beta - \alpha)}{\cos(\alpha + \beta)}$   
 (c)  $\frac{H(\cos\alpha - \cos\beta)}{(\cot\alpha + \cot\beta)}$   
 (d) H

**Answer (a)**

**Sol.** Let AB = h be the height of tower.

Also, F be the point of reflection of D (red bulb).

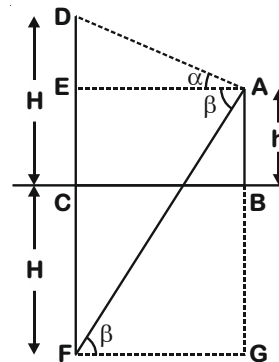

In  $\triangle AED$ ,

$$\tan\alpha = \frac{DE}{AE} = \frac{H-h}{AE}$$

$$\Rightarrow AE = (H-h)\cot\alpha \quad \dots(i)$$

In  $\triangle AGF$ ,

$$\tan\beta = \frac{AG}{FG}$$

$$\Rightarrow \tan\beta = \frac{h+H}{(H-h)\cot\alpha} \quad [\because FG = AE] \text{ [From (i)]}$$

$$\Rightarrow \tan\beta(H-h)\cot\alpha = (h+H)$$

$$\Rightarrow \tan\beta(H-h) = (h+H)\tan\alpha$$

$$\Rightarrow H\tan\beta - h\tan\beta = h\tan\alpha + H\tan\alpha$$

$$\Rightarrow h = \frac{H(\tan\beta - \tan\alpha)}{(\tan\alpha + \tan\beta)}$$

Hence, option (a) is correct.

35. The sum of the roots of  $\frac{1}{x+a} + \frac{1}{x+b} = \frac{1}{c}$  is zero. The product of roots is

- (a) 0                      (b)  $\frac{a+b}{2}$   
 (c)  $-\frac{1}{2}(a^2 + b^2)$       (d)  $2(a^2 + b^2)$

Answer (c)

Sol.  $\frac{1}{x+a} + \frac{1}{x+b} = \frac{1}{c}$

$$\Rightarrow \frac{x+b+x+a}{x^2 + (a+b)x + ab} = \frac{1}{c}$$

$$\Rightarrow (2x + a + b) \times c = x^2 + (a + b)x + ab$$

$$\Rightarrow x^2 + x(a + b - 2c) + ab - ac - bc = 0$$

$$\therefore \text{Sum of roots} = \frac{-(a+b-2c)}{1} = 0$$

$$\Rightarrow a + b = 2c$$

$$\Rightarrow c = \frac{(a+b)}{2} \quad \dots(i)$$

$$\begin{aligned} \text{Product of roots} &= ab - ac - bc \\ &= ab - c(a + b) \\ &= ab - \frac{(a+b)^2}{2} \quad [\text{From (i)}] \\ &= -\frac{1}{2}(a^2 + b^2) \end{aligned}$$

Hence, option (c) is correct.

36. In the convex quadrilateral ABCD, the diagonals AC and BD meet at O and the measure of angle AOB is  $30^\circ$ . If the areas of triangle AOB, BOC, COD and AOD are 1, 2, 8 and 4 square units respectively, what is the product of the lengths of the diagonals AC and DB in sq. units?

- (a) 60                      (b) 56  
 (c) 54                      (d) 64

Answer (a)

Sol.

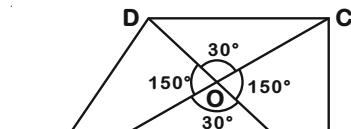

Area of triangle OAB = 1

$$\Rightarrow \frac{1}{2} \times OA \times OB \sin 30^\circ = 1$$

$$\Rightarrow OA \times OB = 4 \quad \dots(i)$$

Similarly,

$$OB \times OC = 8 \quad \dots(ii)$$

$$OC \times OD = 32 \quad \dots(iii)$$

$$OA \times OD = 16 \quad \dots(iv)$$

From (i) and (ii),

$$OC = 2(OA)$$

$$\therefore AC = 3 \times OA \quad \dots(v)$$

$$\text{Now, } OA \times OB = 4 \quad [\text{From (i)}]$$

$$2(OA) \times OD = 32 \quad [\text{From (iii)}]$$

$$\Rightarrow OD = 4 \times OB$$

$$\therefore BD = 5 \times OB$$

$$\begin{aligned} \therefore AC \times BD &= 3 \times 5 \times (OA \times OB) \\ &= 15 \times 4 \quad [\text{From (i)}] \\ &= 60 \end{aligned}$$

$\therefore$  Option (a) is correct.

37. If  $\tan\theta + \sec\theta = 1.5$ , then value of  $\sin\theta$  is

- (a)  $\frac{5}{13}$                       (b)  $\frac{12}{13}$   
 (c)  $\frac{3}{5}$                       (d)  $\frac{2}{3}$

Answer (a)

Sol. We have

$$\sec^2\theta - \tan^2\theta = 1$$

$$(\sec\theta - \tan\theta) = \frac{1}{\sec\theta + \tan\theta}$$

$$= \frac{1}{1.5} = \frac{2}{3} \quad \dots(i)$$

$$\text{and } \sec\theta + \tan\theta = 1.5 = \frac{3}{2} \quad \dots(ii)$$

On solving equation (i) and (ii), we get

$$\sec\theta = \frac{13}{12}$$

In  $\triangle ABC$

$$AB^2 = AC^2 - BC^2$$

$$AB^2 = 13^2 - 12^2$$

$$AB = 5$$

$$\therefore \sin\theta = \frac{AB}{AC} = \frac{5}{13}$$

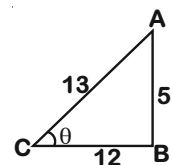

Option (a) is correct.

38. If  $\sin^2x + \sin^2y + \sin^2z = 0$ , then which of the following is NOT a possible value of  $\cosx + \cosy + \cosz$ ?

- (a) 3
- (b) -3
- (c) -1
- (d) -2

Answer (d)

Sol.  $\therefore \sin^2x + \sin^2y + \sin^2z = 0$

$$\Rightarrow \sinx = \siny = \sinz = 0$$

$$\therefore \cosx = \pm 1; \cosy = \pm 1; \cosz = \pm 1$$

$$\therefore \cosx + \cosy + \cosz \text{ can be either } 1 + 1 + 1 = 3$$

$$\text{or } 1 + 1 - 1 = 1 \text{ or } -1 - 1 + 1 = -1$$

$$\text{or } -1 - 1 - 1 = -3$$

$$\therefore \cosx + \cosy + \cosz \neq -2$$

$\therefore$  Option (d) is correct.

39. Find the remainder when  $x^{51}$  is divided by  $x^2 - 3x + 2$ .

- (a) x
- (b)  $(2^{51} - 2)x + 2 - 2^{51}$
- (c)  $(2^{51} - 1)x + 2 - 2^{51}$
- (d) 0

Answer (c)

Sol.  $x^2 - 3x + 2 = (x - 1)(x - 2)$

$$\therefore x^{51} = (x - 1)(x - 2) Q(x) + (px + q)$$

$$\text{Put } x = 1 \Rightarrow 1 = (p + q) \quad \dots(i)$$

$$\text{Put } x = 2 \Rightarrow 2^{51} = (2p + q) \quad \dots(ii)$$

Solving equation (i) and (ii), we get

$$p = (2^{51} - 1) \text{ and } q = 2 - 2^{51}$$

$$\therefore \text{Remainder} = (px + q) = (2^{51} - 1)x + (2 - 2^{51})$$

Option (c) is correct.

40. In an equilateral triangle, three coins of radii 1 unit each are kept so that they touch each other and also sides of the triangle. The area of triangle ABC (in sq. units) is

- (a)  $4 + 2\sqrt{3}$
- (b)  $4\sqrt{3} + 6$
- (c)  $12 + \frac{7\sqrt{3}}{4}$
- (d)  $3 + \frac{7\sqrt{3}}{4}$

Answer (b)

Sol. In  $\triangle AEO$ ,

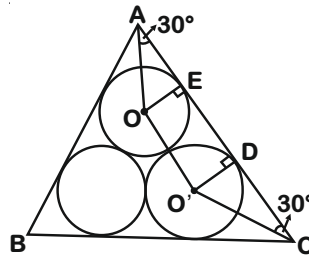

$$\tan 30^\circ = \frac{OE}{AE}$$

$$\Rightarrow AE = \sqrt{3} \quad [\because OE = 1]$$

Similarly,  $DC = \sqrt{3}$

$$\therefore AC = AE + DC + DE$$

$$= \sqrt{3} + 2 + \sqrt{3}$$

$$= 2(1 + \sqrt{3}) \quad \dots(i)$$

$$\text{Required area } (\triangle ABC) = \frac{\sqrt{3}}{4} \times (AC)^2$$

$$= \frac{\sqrt{3}}{4} [4 \times (3 + 1 + 2\sqrt{3})]$$

[from (i)]

$$= (4\sqrt{3} + 6) \text{ sq. units}$$

Hence, option (b) is correct.

41. In case of mice coat colour, two genes are responsible for colour of the hair. Gene 'A' is responsible for distribution of pigments on shaft of hair. Wild type allele of 'A' produces a yellow band on dark hair shaft (agouti), whereas recessive allele produces no yellow band. There is another allele of A, known as  $A^Y$ , which is embryonic lethal in homozygous condition only. In an experiment, two yellow mice were crossed to obtain a progeny of 6 pups. What would be the most probable number of agouti mice among them?

- (a) 0
- (b) 2
- (c) 4
- (d) None of the above

Answer (b)

**Sol.** In this experiment, three cases are possible

(i) Agouti × Agouti = All Agouti

(ii) Yellow × Yellow =  $\frac{2}{3}$  Yellow,  $\frac{1}{3}$  Agouti

(iii) Agouti × Yellow =  $\frac{1}{2}$  Yellow,  $\frac{1}{2}$  Agouti

According to the given statement in question,

i.e., Yellow × Yellow

that mean  $\frac{2}{3}$  Yellow and  $\frac{1}{3}$  Agouti

So, most probable number of agouti mice

would be =  $6 \times \frac{1}{3} = 2$

42. A stain was developed by a group of scientists to stain a particular cell organelle. The stain was tested on various tissues derived from an autopsy sample from a mammal. The organelles were counted. The results showed maximum number of the organelles in cells of brain, lesser in cells of heart, least in mature sperms and absent in erythrocytes. Identify the organelles from following options.

(a) Nissl bodies

(b) Mitochondria

(c) Golgi bodies

(d) Endoplasmic reticulum

**Answer (a)**

**Sol.** Mitochondria, Golgi bodies and Endoplasmic reticulum are the organelles absent in enucleated erythrocytes of mammals whereas Nissl's bodies are present in neural tissue which is maximally concentrated in brain.

43. *Pinus sylvestris* grows at low temperatures in Russia. The plant survives under such freezing conditions due to the presence of :

(a) Saturated lipids in plasma membrane

(b) Glycoproteins in plasma membrane

(c) Glycolipids in plasma membrane

(d) Polyunsaturated lipids in plasma membrane

**Answer (d)**

**Sol.** *Pinus sylvestris* grows at low temperatures in Russia. The plant survives under such freezing conditions due to the presence of polyunsaturated lipids in plasma membrane as these lipids have a lower melting point and more flexibility than the phospholipids with saturated acyl chains.

44. In an experimental setup, certain pathogen caused a disease in primates with nasal congestion, sore throat and fever being the common symptoms. The scientists injected an extract from blue-green mold as the first line of action. However, the symptoms did not subside. The possible causative agents of the disease were listed out as follows.

i. A virus

ii. A fungus

iii. A conjugation deficient bacterium

iv. A tapeworm

Choose the correct option from the following that indicate the pathogen.

(a) i, ii

(b) i, iii

(c) ii, iv

(d) iii only

**Answer (b)**

**Sol.** Administration of extract from blue-green mold (fungi) did not subside the symptoms possibly because the causative agents of the disease may be virus, bacteria or helminth but not fungus. So, the most appropriate answer is option (b).

45. A group of students was studying development of an organism under controlled laboratory conditions. Following observations were made by them.

i. The larvae had a rod-like supporting structure that separated the nervous system and the gut.

- ii. A prominent central cavity was present in the transverse section of the part of the nervous system of the larvae; while the adults had cerebral ganglia as the main component of the nervous system.
- iii. The eyes were prominently seen in larvae.
- iv. The tails were absent in the adults, which the larvae had.
- v. A lot of phagocytic activity was observed before conversion of larvae into adults.
- vi. The adults had a cuticular exoskeleton.

The organism under study must be belonging to:

- (a) Amphibia                      (b) Pisces
- (c) Protochordata              (d) Arthropoda

**Answer (c)**

**Sol.** “Arthropods are non-chordates i.e. lack notochord which is a rod-like supporting structure that separates nervous system and gut as in case of chordates such as Amphibians, fishes and Protochordates. Adult Amphibians and fishes have a well developed nervous system while adult protochordates had cerebral ganglia as nervous system.

Although both amphibians and protochordates exhibit ‘tadpole’ larval stage with prominent eyes and tails but exoskeleton is present only in protochordates (tunicates). Therefore, answer is protochordates.”

46. A process is represented in the adjacent figure. The arrows indicate the flow of a biochemical reaction. The arrowhead points to the product, while the base of the arrow indicates the template biomolecule. What do P, Q, R, and S represent?

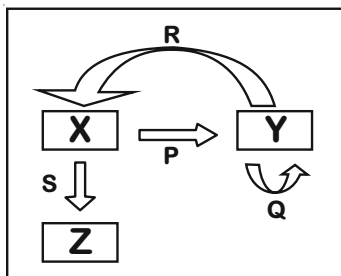

- (a) P : Replication, Q : Translation, R : Transcription, S : Reverse Transcription
- (b) P : Transcription, Q : Replication, R : Reverse Transcription, S : Translation
- (c) P : Reverse Transcription, Q : Replication, R : Translation, S : Transcription
- (d) P : Reverse Transcription, Q : Replication, R : Transcription, S : Translation

**Answer (d)**

**Sol.**

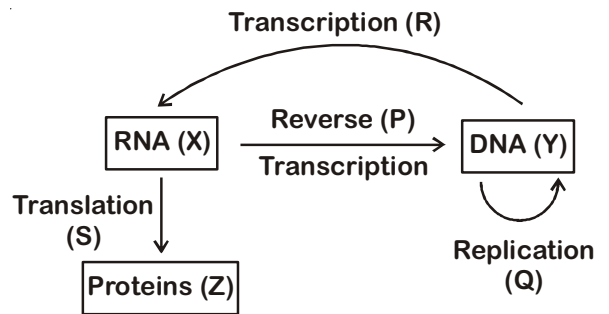

Here, ‘Y’ represents DNA which produces its new copies by the process of ‘Replication’ represented by ‘Q’. RNA is formed from DNA by the process called ‘Transcription’ which is here represented by ‘R’. RNA are translated into proteins by the process called ‘Translation’, represented by ‘S’ here.

In certain viruses, DNA can be synthesized from RNA by the process of ‘Reverse transcription’, represented by ‘P’.

Therefore, P is reverse transcription

Q is replication

R is transcription

and S is translation

47. The whooping cranes were on the verge of extinction with only 21 individuals in wild in 1941. After conservation measures, the cranes are now included in the endangered category by IUCN. The highlight of the conservation efforts is the reintroduction of the whooping cranes in wild. This was possible due to raising of the young cranes in absence of their parents by biologists dressed in crane costumes. Aircraft Guided bird migration technique was used for teaching the captive-bred cranes to follow the scientists to learn the migratory route. What type of animal behaviour might be responsible for these captive-bred cranes to follow the crane costume dressed scientists?

- (a) Cognitive learning
- (b) Habituation
- (c) Operant conditioning
- (d) Genetic Imprinting

**Answer (d)**

**Sol.** The type of animal behaviour responsible for these captive-bred cranes to the crane costume dressed scientists is genetic imprinting which is a rapid learning process that takes place early in the life of a social animal and establishes a behaviour pattern such as recognition of and attraction to its own kind or a substitute.

48. In the baking industry, when the dough is prepared, various ingredients are mixed together with the flour. At one instance, the dough was fermented, but failed to rise sufficiently during the baking process. Choose the correct cause(s) from following possibilities.

- i. The salt was mixed before the fermentation process was completed
  - ii. The sugar was added in excess
  - iii. Yeast granules were not activated prior to mixing with the flour.
- (a) i, iii                      (b) iii only  
(c) i, ii, iii                 (d) i, ii

**Answer (c)**

**Sol.** Addition of salt in the dough slows down fermentation and enzyme activity in dough. Excess sugar in dough can slow down or even inhibit yeast activity. As sugar level increases, yeast becomes stressed as less water is available for it to function. Inactivated yeast granules consist of yeast cells that are no longer living or active and reduces mix time and creates a more extensible dough once they are activated.

49. Given below are four statements.
- I. Prokaryotic cells are unicellular while eukaryotes are multicellular.
  - II. Histones are present in eukaryotes and absent in prokaryotes.
  - III. The nucleoid contains the genetic material in prokaryotes and eukaryotes.
  - IV. Prokaryotic flagellum is composed of flagellin while eukaryotic flagellum is composed of tubulin.

Identify which amongst these are false.

- (a) I and II                      (b) III and IV  
(c) II and III                 (d) I and III

**Answer (d)**

**Sol.** All eukaryotes are not multicellular. For example, protists are unicellular eukaryotes. The region that contains genetic material in prokaryotes is called nucleoid whereas in eukaryotes it is called nucleus.

50. The students of a college were working on regeneration using *Planaria* (Platyhelminthes) and *Asterias* (Echinodermata). *Planaria* was cut in three pieces, namely, a piece with head, with tail and the middle piece. *Asterias* (bearing five arms) was cut in such a way that after separation, six pieces were obtained, namely, an arm with a portion of the central disc, four pieces cut from tips of each of the remaining arms and the remaining body. The animals were allowed to regenerate completely. How many *Planaria* and *Asterias* respectively will be obtained after the completion of regeneration in both?

- (a) 1, 1                              (b) 3, 2  
(c) 3, 6                              (d) 1, 2

**Answer (b)**

**Sol.** Planarians possess a tremendous power of regeneration. If cut across into three parts, each part regenerates into a complete normal individual.

In case of *Asterias*, body part with the portion of central disc can regenerate an entire animal four pieces cut from tips of each of the remaining arms are devoid of central disc, hence, cannot regenerate while the remaining body with remaining central disc can regenerate an entire animal.

Therefore, after the completion of regeneration in *Asterias* total two organisms will be obtained.

51. Fecundity in animal world is the maximum possible ability of an individual to produce offsprings during its entire lifetime. Following factors were checked for their effect on fecundity of different animal models.

- i. Availability of food during breeding season
- ii. Mode of fertilization
- iii. Population density

Which of these factors(s) can regulate fecundity?

- (a) i, ii  
(b) ii, iii  
(c) i, ii, iii  
(d) None of the above



**Answer (c)**

**Sol.** All the given factors *i.e.* the availability of food during breeding season, mode of fertilization and population density affect the fecundity of animals.

52. An organism has 27 pairs of homologous chromosomes. In each daughter cell after completion of mitosis and in each gamete after completion of meiosis II, \_\_\_\_\_ and \_\_\_\_\_ chromosomes would be present respectively.

- (a) 27 and 27                      (b) 54 and 27  
(c) 108 and 54                    (d) 54 and 108

**Answer (b)**

**Sol.** In mitosis, mother cell divides to form two identical daughter cells which have the same number of chromosomes as mother cell. Hence, each daughter cell would have 27 pairs or 54 chromosomes.

Meiosis is a reductional division which involves two consecutive divisions. The daughter cells have half the number of chromosomes than that of mother cell. Hence, in each gamete, after completion of meiosis-II, 27 chromosomes would be present.

53. Rahul sprayed a chemical 'X' on a plant with rosette habit. After few days, he found the internodal distances to have increased suddenly. The chemical 'X' might be:

- (a) Ethylene                      (b) Abscisic acid  
(c) Auxin                          (d) Gibberellic acid

**Answer (d)**

**Sol.** The sprayed chemical 'X' is Gibberellic acid which induces internodal and stem elongation in rosette plants.

54. In case of peppered moths, pale and dark moths are observed. Pale variety is known to be the wild type variety. During industrial revolution, industrial melanism led to prevalence of dark variety around the cities and pale variety continued to be in majority in areas away from the industries. After enforcement of regulations for controlling pollution, reappearance of pale moths in majority was observed around cities again. Driving force(s) for these adaptive changes is/ are:

- i. Increased pollution around industries
- ii. A stable transposition of a gene in moths
- iii. Limitations of the vision of birds to differentiate dark moths on darkened barks and pale moths in presence of lichens
- iv. Ability of lichens to grow on barks in less polluted areas only.

- (a) i, iv                              (b) i, iii, iv  
(c) i, ii                                (d) i, ii, iii and iv

**Answer (b)**

**Sol.**

Pre-Industrial Period	Post-Industrial Period
• No air pollution	• Pollution increased
• Tree trunk lighter in colour	• Tree trunk darken
• No smoke deposition and thick growth of white coloured lichens on tree trunk	• Smoke and soot deposition on trunk preventing lichens growth
• Less predation of pale moth	• Dark moths are not visible while pale moths cannot camouflage causing limitations of vision of birds leading more predation of pale moths

55. A 4 µm long bacterial cell was magnified and drawn to a dimension of 6 cm. How many times has it been magnified?

- (a)  $1.5 \times 10^3$                       (b)  $15 \times 10^4$   
(c)  $1.5 \times 10^4$                       (d) 1.5

**Answer (c)**

**Sol.** Size of bacterial cell = 4 µm =  $4 \times 10^{-6}$  m

Size of drawn cell = 6 cm =  $6 \times 10^{-2}$  m

$$\text{So, bacterial cell magnification} = \frac{6 \times 10^2}{4 \times 10^{-6}} \\ = 1.5 \times 10^4$$

56. Gymnosperms are called 'naked seed bearing plants' because they lack:

- (a) Male gamete                      (b) Ovule  
(c) Ovary                                (d) Seeds

**Answer (c)**

**Sol.** Gymnosperms are called 'naked seeds bearing plants' because they lack ovary. The seeds are not enclosed within the fruit.

57. Any damage or injury to a particular area causes nociceptors to release some chemicals, which carry the signal to the higher centres in the nervous system for the processing and a subsequent action. However, there is a difference in the way in which the stimulus is received which is related to the acuity of the detection. Fingertips are more sensitive as compared to the forearm. Following reasons for the observed phenomenon were suggested.

- The receptive fields in the fingertip are smaller
- The number of nociceptors per receptive field in the forearm is lesser
- The amount of prostaglandins released by the nociceptors per receptive field is more in fingertips

The most probable reason(s) for this may be:

- (a) i                                      (b) i, iii  
 (c) ii, iii                                (d) i, ii, iii

Answer (d)

Sol. In fingertips, the receptive fields are smaller and densely packed with nociceptors or pain receptors. The number of nociceptors and amount of prostaglandins released by these receptors per receptive field is also more in fingertips in comparison to forearm.

58.

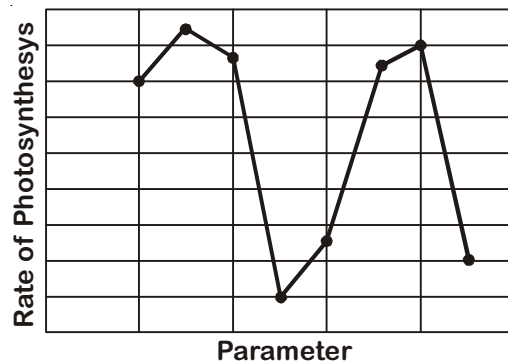

Rate of photosynthesis in hydrophytes depends on various parameters. The adjacent graph shows the effect of one parameter (while keeping all the others constant) on the rate of photosynthesis. Rate of photosynthesis is plotted on Y axis. Identify the parameter which is plotted along X axis:

- Light intensity
- Wavelength
- Temperature
- CO<sub>2</sub> concentration

Answer (b)

Sol. Light between 400-700 nm wavelength constitute the photosynthetically active radiation. Maximum photosynthesis takes place in red and blue light of the visible spectrum and minimum photosynthesis takes place in green light.

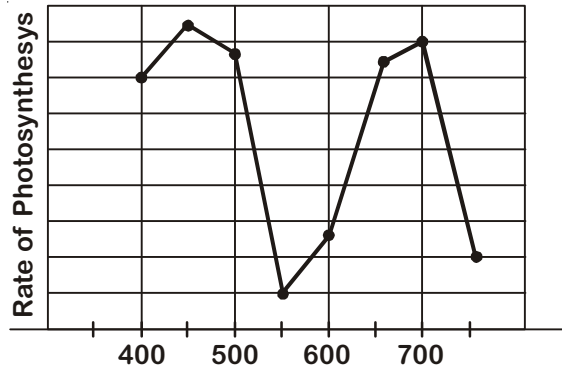

VIBGYOR

59. On a study tour, plants with leathery leaves with thick cuticle, vivipary, salt glands, apogeotropic roots and stomata limited to abaxial surface were observed. The plants might be:

- (a) Bromeliads                              (b) Cycads  
 (c) Mangroves                                (d) None of the above

Answer (c)

Sol. Mangroves are adapted to grow in a wet and salty place. They have leathery leaves with thick cuticle, show vivipary (the young plant within the seed), have salt glands, have apogeotropic roots (roots that grow away from the ground) and have stomata limited to abaxial surface.

60. Four different human body fluid samples were subjected to quantification of hydrogen ion concentration. mEq/L is the unit of measurement for hydrogen ion concentration. The results of the experiment were as follows:

- Sample A:  $1.6 \times 10^2$  units  
 Sample B:  $4.5 \times 10^{-5}$  units  
 Sample C:  $1 \times 10^{-3}$  units  
 Sample D:  $3 \times 10^{-2}$  units

Identify the samples in sequence from A to D.

- Gastric HCl, Venous blood, Intracellular Fluid, Urine
- Venous blood, Intracellular Fluid, Gastric HCl, Urine
- Urine, Gastric HCl, Venous blood, Intracellular Fluid
- Intracellular Fluid, Urine, Gastric HCl, Venous blood

**Answer (a)**

**Sol.** Higher the amount of hydrogen ions, lower will be the pH of body fluid.

On this basis we can conclude that

Sample A with maximum hydrogen ions concentration facilitate lowest pH among the given samples indicating that sample A is gastric HCl.

Samples	H <sup>+</sup> ion concentration (m Eq/L)	Human Body Fluids
A	$1.6 \times 10^2$ = 160	Gastric HCl
B	$4.5 \times 10^{-5}$ = 0.000045	Venous blood
C	$1 \times 10^{-3}$ = 0.001	Intracellular fluid
D	$3 \times 10^{-2}$ = 0.03	Urine

Sequence of sample = Gastric HCl, Venous blood, Intracellular fluid, Urine.

61. Four gram of mixture of calcium carbonate and sand is treated with excess of HCl and 0.880 g of carbon-di-oxide is produced. What is the percentage of calcium carbonate in original mixture?

- (a) 40%
- (b) 50%
- (c) 55%
- (d) 45%

**Answer (b)**

**Sol.** 4 g mixture of CaCO<sub>3</sub> + sand

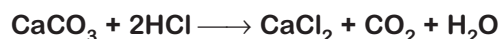

Number of moles of CO<sub>2</sub> produced

$$= \frac{0.88}{44}$$

$$= 0.02 \text{ moles}$$

- ∴ 1 mol of CaCO<sub>3</sub> produces 1 mol of CO<sub>2</sub>
- ∴ Number of moles of CaCO<sub>3</sub> reacted = 0.02 moles
- ∴ Mass of CaCO<sub>3</sub> reacted = 0.02 × 100 = 2 g
- ∴ % of CaCO<sub>3</sub> in the mixture =  $\frac{2}{4} \times 100 = 50\%$

62.

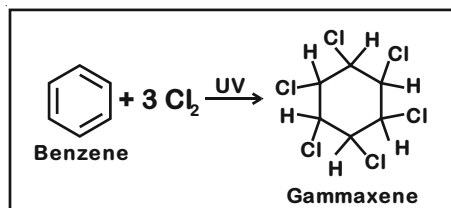

Gammaxene insecticide powder is prepared by the reaction given in the adjacent box. If 78 g of benzene when reacted with 106.5 g of chlorine, how much Gammaxene would be formed?

- (a) 140 g
- (b) 154.5 g
- (c) 145.5 g
- (d) 160 g

**Answer (c)**

**Sol.**

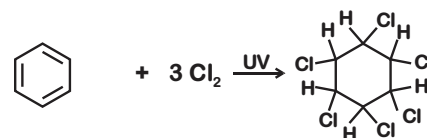

Given mass 78g 106.5g

No. of moles  $\frac{78}{78} = 1 \text{ mole}$   $\frac{106.5}{71} = 1.5 \text{ mole}$

Cl<sub>2</sub> is the limiting reagent

- ∴ 3 moles of Cl<sub>2</sub> produce 1 mole of gammaxene
- ∴ 1.5 moles of Cl<sub>2</sub> produce 0.5 mole of gammaxene

Mass of 1 mole of gammaxene = 291 g

∴ Mass of 0.5 moles of gammaxene = 291 × 0.5 = 145.5 g

63. Which of the following polymeric material will be ideal for remoulding?

- (a) Polythene and Melamine
- (b) Polyvinyl chloride and Polythene
- (c) Melamine and Bakelite
- (d) Bakelite and Polyvinyl chloride

**Answer (b)**

**Sol.** Polyvinyl chloride and polythene are thermoplastics and therefore they are ideal for remoulding.

64. An element Y is a white translucent solid at room temperature and exhibits various allotropic forms. Some compounds of element Y find application in agricultural industry. Y forms two solid oxides which dissolve in water to form comparatively weak acids. The element Y is:

- (a) Sulphur
- (b) Nitrogen
- (c) Phosphorous
- (d) Carbon

**Answer (c)**

**Sol.** Oxides of carbon, sulphur and nitrogen are gases, whereas oxides of phosphorus i.e. P<sub>4</sub>O<sub>6</sub> and P<sub>4</sub>O<sub>10</sub> are solids and react with water to give weak acids.

Therefore, element 'Y' is phosphorus.

65. How many sigma bonds are present between any two carbon atoms in fullerenes?

- (a) 1 (b) 2  
(c) 3 (d) 4

Answer (a)

Sol. In fullerenes, one sigma bond is present between any two carbon atoms.

66. A student was studying reactions of metals with dilute NaOH at room temperature. The student took dilute NaOH in four different test tubes and added copper powder to test tube A, zinc dust to test tube B, aluminium powder to test tube C and iron powder to test tube D and observed effervescence in \_\_\_\_\_.

- (a) Test tubes A & B (b) Test tubes B & C  
(c) Test tubes C & D (d) Test tubes A & D

Answer (b)

Sol. In test tube 'B' and 'C' effervescence will be observed due to the evolution of hydrogen gas, whereas in test tube 'A' and 'D', no such effervescence will be observed.

67. A magician performed following act: He dipped Rs. 50 note in a 50% solution of alcohol in water and held it on the burning flame, but the note did not burn. The reason behind this is

- (a) The alcohol kept on dousing the fire  
(b) Air required for burning was not available  
(c) The Rs. 50 note failed to reach ignition temperature  
(d) The Rs. 50 note is fire proof

Answer (c)

Sol. The heat supplied to the Rs. 50 note is transferred to water by conduction. So, in the presence of 50% solution of alcohol in water, the ignition temperature of paper is not reached. Hence, it does not burn.

68. Substance X is white crystalline solid which melts after 10 seconds on burner flame. It is soluble in water and insoluble in  $\text{CCl}_4$ . It is a poor conductor of electricity in molten state as well as in the form of aqueous solution, hence we conclude that substance X is

- (a) An ionic compound  
(b) A non-polar covalent compound  
(c) A polar covalent compound  
(d) A pure element

Answer (c)

Sol. Since substance X melts after 10 seconds on burner flame and is a poor conductor of electricity in molten state as well as in the form of aqueous solution, this means 'X' is a covalent compound. Its solubility in water indicates that it is polar in nature.

∴ 'X' is a polar covalent compound.

69. In a beaker 50 ml of a normal HCl solution was taken and  $\text{NH}_3$  gas was passed through it for some time. The contents of the beaker were then titrated, which required 60 ml of semi normal NaOH solution. How much ammonia was passed through the beaker?

- (a) 0.85 g (b) 0.34 g  
(c) 0.51 g (d) 0.4 g

Answer (b)

Sol. Milliequivalent of NaOH =  $NV_{\text{ml}}$   
 $= 0.5 \times 60$   
 $= 30$

Milliequivalent of HCl =  $NV_{\text{ml}} = 1 \times 50 = 50$

In neutralisation reaction;

Total milliequivalent of HCl = Milliequivalent of  $\text{NH}_3$  +  
Milliequivalent of NaOH

$50 = \text{Milliequivalent of } \text{NH}_3 + 30$

Milliequivalent of  $\text{NH}_3 = 50 - 30 = 20$

Moles of  $\text{NH}_3 = 20 \times 10^{-3}$  moles

Mass of  $\text{NH}_3 = 20 \times 10^{-3} \times 17 = 0.34$  g

70. Which is the correct order of metals with reference to their melting point in increasing order?

- (a) Hg, Ga, Li, Ca  
(b) Ca, Li, Ga, Hg  
(c) Hg, Li, Ga, Ca  
(d) Hg, Ga, Ca, Li

Answer (a)

Metal	Melting point
Hg	234 K
Ga	303 K
Li	454 K
Ca	1124 K

Therefore, the correct arrangement of metals in the increasing order of their melting point is

$\text{Hg} < \text{Ga} < \text{Li} < \text{Ca}$

71. Which of the following is iso-structural with  $\text{CO}_2$ ?

- (a)  $\text{NO}_2$                       (b)  $\text{N}_2\text{O}_4$   
 (c)  $\text{NO}$                         (d)  $\text{N}_2\text{O}$

Answer (d)

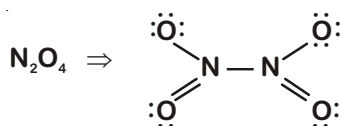
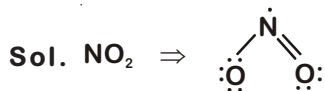

$\therefore \text{N}_2\text{O}$  is iso-structural with  $\text{CO}_2$ .

72. Sodium tungstate has formula  $\text{Na}_2\text{WO}_4$ , lead phosphate has formula  $\text{Pb}_3(\text{PO}_4)_2$ , formula for lead tungstate should be:

- (a)  $\text{PbWO}_4$                       (b)  $\text{Pb}_2(\text{WO}_4)_3$   
 (c)  $\text{Pb}_3(\text{WO}_4)_2$                 (d)  $\text{Pb}_3(\text{WO}_4)_4$

Answer (a)

Sol.  $\text{Na}_2\text{WO}_4$  indicates, valency of  $\text{WO}_4 = -2$

$\text{Pb}_3(\text{PO}_4)_2$  indicates, valency of  $\text{Pb} = +2$

$\therefore$  Chemical formula of lead tungstate =  $\text{PbWO}_4$

73. What is the ratio of reducing agent to oxidizing agent, if the following reaction is correctly balanced?  $\text{NH}_3 + \text{O}_2 \rightarrow \text{NO} + \text{H}_2\text{O}$

- (a) 4 : 5                          (b) 5 : 4  
 (c) 5 : 3                          (d) 3 : 5

Answer (a)

Sol. In the balanced reaction,

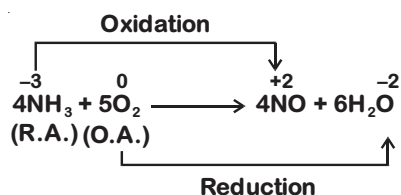

$\therefore$  Reducing agent : Oxidizing agent

4 : 5

74. Arrange following solutions in increasing hydronium ion concentration. The solutions are:

(P) 0.1 M  $\text{HCl}$  (Q) 0.1 M  $\text{H}_2\text{SO}_4$  (R) 0.001 M  $\text{NH}_4\text{OH}$  (S) 0.001 M  $\text{Ca}(\text{OH})_2$

The correct order will be

- (a)  $\text{P} > \text{Q} > \text{R} > \text{S}$             (b)  $\text{Q} > \text{P} > \text{S} > \text{R}$   
 (c)  $\text{S} > \text{R} > \text{Q} > \text{P}$             (d)  $\text{S} > \text{R} > \text{P} > \text{Q}$

Answer (\*)

Sol. P : 0.1 M  $\text{HCl}$  gives 0.1 M  $\text{H}^+ = 10^{-1}$  M  $\text{H}^+$

Q : 0.1 M  $\text{H}_2\text{SO}_4$  gives  $2 \times 0.1$  M  $\text{H}^+$   
 $= 2 \times 10^{-1}$  M  $\text{H}^+$

R : 0.001 M  $\text{NH}_4\text{OH}$  gives 0.001 M  $\text{OH}^-$   
 $= 10^{-3}$  M  $\text{OH}^-$

$$\begin{aligned}
 \text{Concentration of } \text{H}^+ &= \frac{K_w}{[\text{OH}^-]} = \frac{10^{-14}}{10^{-3}} \\
 &= 10^{-11} \text{ M } \text{OH}^-
 \end{aligned}$$

S : 0.001 M  $\text{Ca}(\text{OH})_2$  gives  $2 \times 0.001$  M  $\text{OH}^-$   
 $= 2 \times 10^{-3}$  M  $\text{OH}^-$

$$\begin{aligned}
 \text{Concentration of } \text{H}^+ &= \frac{k_w}{[\text{OH}^-]} = \frac{10^{-14}}{2 \times 10^{-3}} \\
 &= 5 \times 10^{-12} \text{ M } \text{H}^+
 \end{aligned}$$

So, correct order of hydronium ion concentration is  $\text{S} < \text{R} < \text{P} < \text{Q}$

\* None of the given option is correct.

75. A zinc rod was dipped in 100  $\text{cm}^3$  of 1M copper chloride solution. After certain time the molarity of  $\text{Cu}^{2+}$  ions in the solution was found to be 0.8 M. If the weight of zinc rod is 20 g, then the molarity of chloride ions is \_\_\_\_\_.

- (a) 2 M  
 (b) 1.5 M  
 (c) 1 M  
 (d) 0.5 M

Answer (a)

Sol. When Zn rod is dipped in copper chloride solution, following reaction takes place:

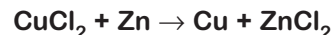

All the chloride ions will remain in solution.

$\therefore$  Molarity of  $\text{Cl}^-$  ions =  $2 \times 1 = 2$  M.

76. When four dilute solutions of (I) vinegar, (II) common salt, (III) caustic soda and (IV) baking soda are tested with universal indicator which will be the correct observation

- (a) I - Green, II - Violet, III - Blue, IV - Red  
 (b) I - Green, II - Blue, III - Violet, IV - Red  
 (c) I - Red, II - Green, III - Violet, IV - Blue  
 (d) I - Red, II - Violet, III - Green, IV - Blue

Answer (c)

Dilute solution	Nature of solution	Colour shown with universal indicator
Vinegar (I)	Acidic	Red
Common salt (II)	Neutral	Green
Caustic soda (III)	Strongly basic	Violet
Baking soda (IV)	Mildly basic	Blue

77. In one litre of pure water, 44.4 g of calcium chloride is dissolved. The number of ions in one mL of the resultant solution is:

- (a)  $7.23 \times 10^{23}$       (b)  $7.23 \times 10^{20}$   
 (c)  $4.82 \times 10^{23}$       (d)  $4.82 \times 10^{20}$

Answer (b)

Sol. Number of moles of  $\text{CaCl}_2 = \frac{\text{Given mass}}{\text{Molecular mass}}$   

$$= \frac{44.4}{111} = 0.4 \text{ mole}$$

- $\therefore$  1 litre solution contain 0.4 mole of  $\text{CaCl}_2$   
 $\therefore$  1 mL solution contain 0.0004 mole of  $\text{CaCl}_2$   
 $\therefore$  One  $\text{CaCl}_2$  ionized into one  $\text{Ca}^{2+}$  and  $2\text{Cl}^-$  ions.

So, the total number of ions = 3

$\therefore$  Total ions in 1 mL  
 $= 3 \times 0.0004 \times 6.022 \times 10^{23}$   
 $= 7.23 \times 10^{20}$

78. Which of the following species is/are isoelectronic with Neon?

- (i)  $\text{N}^{3-}$       (ii)  $\text{Mg}^{2+}$   
 (iii)  $\text{K}^+$       (iv)  $\text{Ca}^{2+}$   
 (a) Only (iv)      (b) Only (ii)  
 (c) Both (i) & (ii)      (d) Both (i) & (iii)

Answer (c)

Sol.

Element/ion	Atomic Number (Z)	Electronic configuration			
		K	L	M	N
Ne	10	2	8		
$\text{N}^{3-}$	7	2	8		
$\text{Mg}^{2+}$	12	2	8		
$\text{K}^+$	19	2	8	8	
$\text{Ca}^{2+}$	20	2	8	8	

As Ne,  $\text{N}^{3-}$  and  $\text{Mg}^{2+}$  have same number of electrons i.e., 10 electrons. So Ne,  $\text{N}^{3-}$  and  $\text{Mg}^{2+}$  are isoelectronic species.

79. Which of the following gases will have equal volume at STP, if the weight of gases is 14.0 g?

- (i)  $\text{N}_2\text{O}$       (ii)  $\text{NO}_2$   
 (iii)  $\text{N}_2$       (iv) CO  
 (a) (i) & (ii)      (b) (ii) & (iii)  
 (c) (i) & (iii)      (d) (iii) & (iv)

Answer (d)

Gas	Molecular mass (u)	Number of Moles
$\text{N}_2\text{O}$	44	$\frac{14}{44} = 0.32$
$\text{NO}_2$	46	$\frac{14}{46} = 0.30$
$\text{N}_2$	28	$\frac{14}{28} = 0.5$
CO	28	$\frac{14}{28} = 0.5$

As  $\text{N}_2$  and CO have same number of moles i.e., 0.5 mole.

$\therefore$   $\text{N}_2$  and CO will have equal volume at STP

i.e.,  $\frac{22.4}{2} \text{L} = 11.2 \text{L}$

80. Which of the following are not ionic?

- (i)  $\text{AlCl}_3$       (ii)  $\text{CaCl}_2$   
 (iii)  $\text{MgCl}_2$       (iv) LiCl  
 (a) (i) & (iv)      (b) (i) & (ii)  
 (c) (ii) & (iii)      (d) (iii) & (iv)

Answer (a)

Sol. Chlorides of aluminium and lithium are predominately covalent in nature.