

JEE Advanced 2020
Question Paper With Text Solutions
PAPER-2
PHYSICS



JEE Main & Advanced | XI-XII Foundation | VI-X Pre-Foundation

Office : Piprali Road, Sikar (Raj.) | Ph. 01572-241911
Website : www.matrixedu.in ; Email : smd@matrixacademy.co.in

**JEE ADVANCED SEP 2020 | 27 SEP PAPER-2****PHYSICS****SECTION-1 (Maximum Marks : 18)**

- * This section contains SIX (06) questions.
- * The answer to each question is a SINGLE DIGIT INTEGER ranging from 0 to 9, BOTH INCLUSIVE.
- * For each question, enter the correct integer corresponding to the answer using the mouse and the on-screen virtual numeric keypad in the place designated to enter the answer.
- * Answer to each question will be evaluated according to the following marking scheme :

Full Marks : +3 If ONLY the correct integer is entered.

Zero Marks : 0 If the question is unanswered.

Negative marks : -1 In all other cases.

1. A large square container with thin transparent vertical walls and filled with water (refractive index $\frac{4}{3}$) is kept on a horizontal table. A student holds a thin straight wire vertically inside the water 12 cm from one of its corners, as shown schematically in the figure. Looking at the wire from this corner, another student sees two images of the wire, located symmetrically on each side of the line of sight as shown. The separation (in cm) between these images is _____.

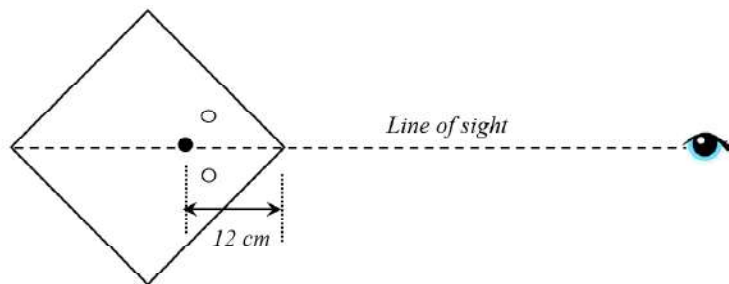

Ans. 3 or (BONUS)

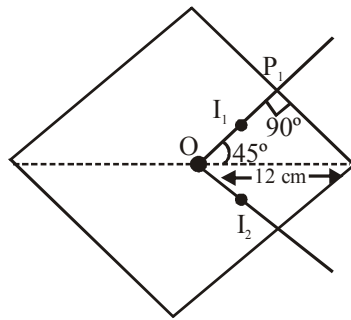

Sol. Sol.

$$\text{Apparent depth } P_1I_1 = \frac{OP_1}{3}$$

$$P_1I_1 = \frac{12 \cos 45^\circ}{4/3} = \frac{9}{\sqrt{2}}$$

$$OI_1 = OP_1 - P_1I_1 = \frac{12}{\sqrt{2}} - \frac{9}{\sqrt{2}} = \frac{3}{\sqrt{2}}$$

$$OI_2 = \frac{3}{\sqrt{2}}$$

$$I_1I_2 = 2 \times OI_1 \cos 45^\circ$$

$$= 2 \times \frac{3}{\sqrt{2}} \times \frac{1}{\sqrt{2}} = 3 \text{ cm.}$$

As line of sight is given in the question so it should be bonus as our solution is based on normal incidence.

2. A train with cross-sectional area S_t is moving with speed v_t inside a long tunnel of cross-sectional area S_0 ($S_0 = 4S_t$). Assume that almost all the air (density ρ) in front of the train flows back between its sides and the walls of the tunnel. Also, the air flow with respect to the train is steady and laminar. Take the ambient pressure and that inside the train to be p_0 . If the pressure in the region between the sides of the train and the tunnel walls is p , then $p_0 - p = \frac{7}{2N} \rho v_t^2$. The value of N is _____.

Ans. 9



Sol.

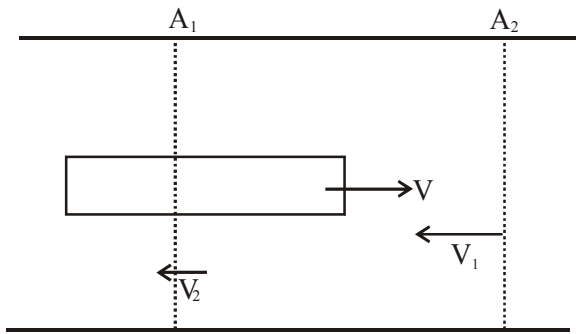

V_1 & V_2 are speed of air relative to train at the two cross sections A_1 & A_2 respectively

$$A_1 = S_0 \text{ \& \ } A_2 = \frac{3}{4} S_0.$$

Applying equation of continuity at the two cross section $A_1 V_1 = A_2 V_2 \Rightarrow V_2 = \frac{4}{3} V$ (i)

Apply bernoulli quation at the two cross sections.

$$P_0 + \frac{\rho V_1^2}{2} = P + \frac{\rho V_2^2}{2}$$

$$\Rightarrow P_0 - P = \frac{\rho}{2} (V_2^2 - V_1^2)$$

$$\Rightarrow P_0 - P = \frac{7\rho v^2}{2 \times 9}$$

$$\therefore N = 9$$

3. Two large circular discs separated by a distance of 0.01 m are connected to a battery via a switch as shown in the figure. Charged oil drops of density 900 kg m^{-3} are released through a tiny hole at the center of the top disc. Once some oil drops achieve terminal velocity, the switch is closed to apply a voltage of 200 V across the discs. As a result, an oil drop of radius $8 \times 10^{-7} \text{ m}$ stops moving vertically and floats between the discs. The number of electrons present in this oil drop is _____. (neglect the buoyancy force, take acceleration due to gravity $= 10 \text{ ms}^{-2}$ and charge on an electron $(e) = 1.6 \times 10^{-19} \text{ C}$)

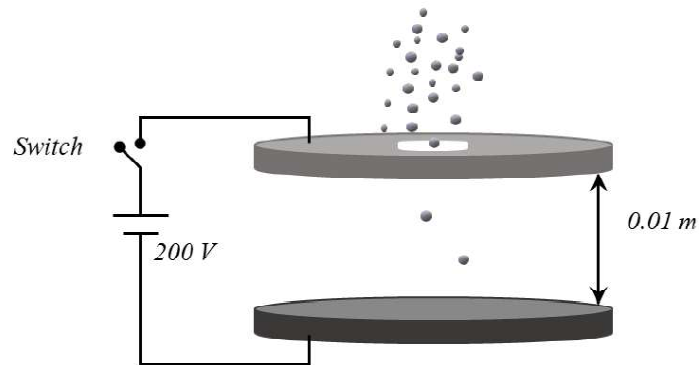

Ans. 6

Sol. As drops are floating so net force on a drop should be zero.

$$mg = qE \quad E = \frac{V}{d} = \frac{200}{0.01} = 2 \times 10^4 \text{ v/m}$$

$$\Rightarrow q = \frac{mg}{E}$$

$$\Rightarrow q = \frac{\frac{4}{3} \pi r^3 \rho g}{E}$$

$$\Rightarrow q = \frac{\frac{4}{3} \times \pi \times (8 \times 10^{-7})^3 \times 900 \times 10}{2 \times 10^4}$$

$$\Rightarrow 9.6 \times 10^{-19}$$

$$\Rightarrow q = 6e$$

$$\therefore N = 6$$



4. A hot air balloon is carrying some passengers, and a few sandbags of mass 1 kg each so that its total mass is 480 kg. Its effective volume giving the balloon its buoyancy is V . The balloon is floating at an equilibrium height of 100 m. When N number of sandbags are thrown out, the balloon rises to a new equilibrium height close to 150 m with its volume V remaining unchanged. If the variation of the density of air with height h from the ground is $\rho(h) = \rho_0 e^{-\frac{h}{h_0}}$, where $\rho_0 = 1.25 \text{ kg m}^{-3}$ and $h_0 = 6000 \text{ m}$, the value of N is _____.

Ans. 4

Sol. As balloon is floating in equilibrium

\therefore Weight = Buoyant force

at Initial position

$$\Rightarrow 480 g = V \rho_{100} \quad \dots(i)$$

at new position N sandbags are thrown

$$\Rightarrow (480 - N) g = V \rho_{150} \quad \dots(ii)$$

(ii) \div (i)

$$\Rightarrow \frac{480 - N}{480} = \frac{\rho_{150}}{\rho_{100}}$$

$$\Rightarrow \frac{480 - N}{480} = e^{\frac{-50}{6000}}$$

$$\Rightarrow \left(1 - \frac{N}{480}\right) = \left(1 - \frac{1}{120}\right)$$

{Use $e^x = 1 + x$ for small x }

$$\Rightarrow N = 4$$



5. A point charge q of mass m is suspended vertically by a string of length l . A point dipole of dipole moment \vec{p} is now brought towards q from infinity so that the charge moves away. The final equilibrium position of the system including the direction of the dipole, the angles and distances is shown in the figure below. If the work done in bringing the dipole to this position is $N \times (mgh)$, where g is the acceleration due to gravity, then the value of N is _____. (Note that for three coplanar forces keeping a point mass in equilibrium, $\frac{F}{\sin \theta}$ is the same for all forces, where F is any one of the forces and θ is the angle between the other two forces)

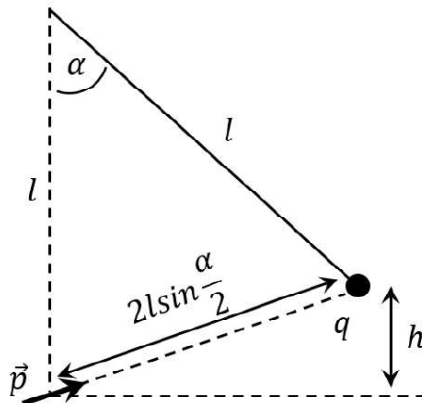

Ans. 2

Sol.

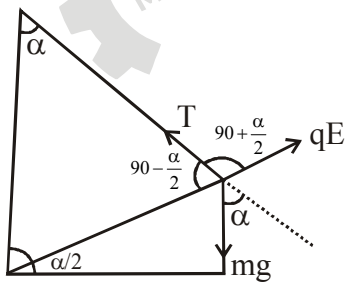

$$E = \frac{2KP}{\left(2l \sin \frac{\alpha}{2}\right)^3} \dots\dots\dots (1)$$

$$V = \frac{KP}{\left(2l \sin \frac{\alpha}{2}\right)^2} \dots\dots\dots (2)$$



As forces are balanced

$$\frac{qE}{\sin(180^\circ - \alpha)} = \frac{mg}{\sin\left(90^\circ + \frac{\alpha}{2}\right)}$$

$$\frac{qE}{\sin \alpha} = \frac{mg}{\cos\left(\frac{\alpha}{2}\right)} \dots\dots\dots (3)$$

$$\left\{ h = 2\ell \sin \frac{\alpha}{2} \times \sin \frac{\alpha}{2} \right\} \dots\dots\dots (4)$$

Wok done = Potential energy = $mgh + qV$

Using (1), (2), (3) & (4)

$$W = mgh + mgh = 2mgh$$

6. A thermally isolated cylindrical closed vessel of height 8 m is kept vertically. It is divided into two equal parts by a diathermic (perfect thermal conductor) frictionless partition of mass 8.3 kg. Thus the partition is held initially at a distance of 4 m from the top, as shown in the schematic figure below. Each of the two parts of the vessel contains 0.1 mole of an ideal gas at temperature 300 K. The partition is now released and moves without any gas leaking from one part of the vessel to the other. When equilibrium is reached, the distance of the partition from the top (in m) will be _____ (take the acceleration due to gravity = 10 ms^{-2} and the universal gas constant = $8.3 \text{ J mol}^{-1}\text{K}^{-1}$).

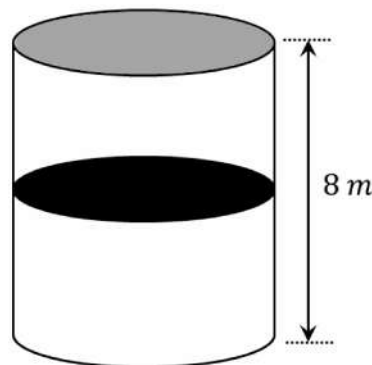

Ans. 6



Sol. Sol.

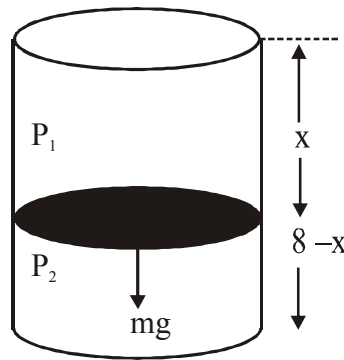

Initially from ideal gas equation

$$P_1 A \times 4 = 0.1 \times R \times (300)$$

x = Final distance of piston from top

assuming constant temperature.

$$P_1 A x = P_2 A (8 - x) = 0.1 \times R \times 300 \dots\dots\dots(1)$$

Piston is in equilibrium

$$P_1 A + mg = P_2 A \dots\dots\dots(2)$$

from equation (1) & (2)

$$\frac{30R}{x} + 10 = \frac{30}{8-x}$$

$$\frac{3}{x} + 1 = \frac{3}{8-x}$$

$$(3x + x)(8 - x) = 3x$$

$$24 - 3x + 8x - x^2 = 3x$$

$$x^2 - 2x - 24 = 0$$

$$x = \frac{2 \pm \sqrt{4 + 96}}{2}$$

$$x = \frac{2 + 10}{2} = 6 \text{ m.}$$

As piston loses gravitational potential energy. So temperature of gas should increase but we do not have information about C_v of gas so we can not find temperature change hence constant temperature is assumed.

**SECTION-2 (Maximum Marks : 24)**

- * This section contains **SIX** (06) questions.
- * Each question has **FOUR** options. **ONE OR MORE THAN ONE** of these four option(s) is (are) correct answer(s).
- * For each question, choose the option(s) corresponding to (all) the correct answer(s).
- * Answer to each question will be evaluated according to the following marking scheme.
Full Marks : +4 If only (all) the correct option(s) is (are) chosen.
Partial Marks : +3 If all the four options are correct but **ONLY** three options are chosen.
Partial Marks : +2 If three or more options are correct but **ONLY** two options are chosen and both of which are correct.
Partial Marks : +1 If two or more options are correct but **ONLY** one option is chosen and it is a correct option.
Zero Marks : 0 If none of the options is chosen (i.e. the question is unanswered).
Negative Marks : -2 In all other cases.

7. A beaker of radius r is filled with water (refractive index $\frac{4}{3}$) up to a height H as shown in the figure on the left. The beaker is kept on a horizontal table rotating with angular speed ω . This makes the water surface curved so that the difference in the height of water level at the center and at the circumference of the beaker is h ($h \ll H$, $h \ll r$), as shown in the figure on the right. Take this surface to be approximately spherical with a radius of curvature R . Which of the following is/are correct? (g is the acceleration due to gravity)

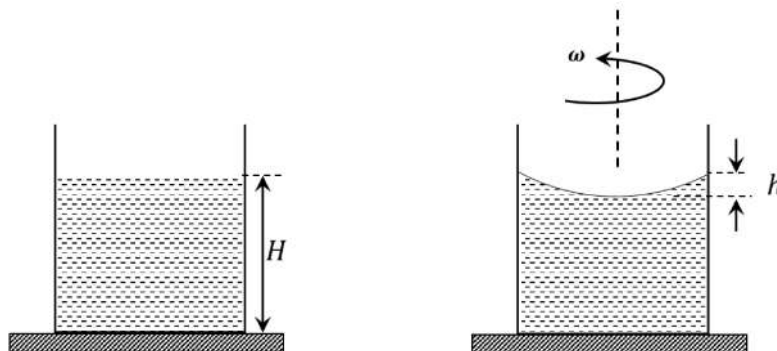
**MATRIX JEE ACADEMY**

Office : Piprali Road, Sikar (Raj.) | Ph. 01572-241911

Website : www.matrixedu.in ; Email : smd@matrixacademy.co.in



(A) $R = \frac{h^2 + r^2}{2h}$

(B) $R = \frac{3r^2}{2h}$

(C) Apparent depth of the bottom of the beaker is close to $\frac{3H}{2} \left(1 + \frac{\omega^2 H}{2g}\right)^{-1}$

(D) Apparent depth of the bottom of the beaker is close to $\frac{3H}{4} \left(1 + \frac{\omega^2 H}{4g}\right)^{-1}$

Ans. A, D

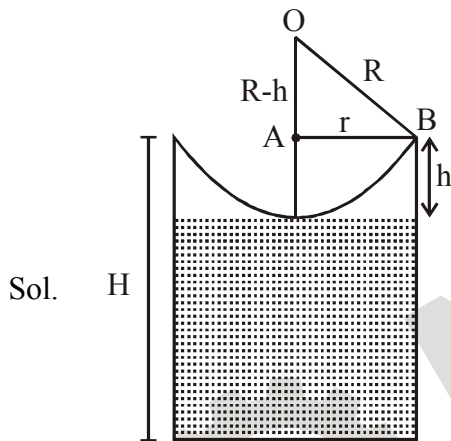

Equation of shape of water $y = \frac{\omega^2 x^2}{2g}$

In ΔOAB

$r^2 + (R-h)^2 = R^2$

$r^2 + R^2 + h^2 - 2Rh = R^2$

$r^2 + h^2 = 2Rh$

$R = \frac{r^2 + h^2}{2h}$

As given $r \gg h$, $R = \frac{r^2}{2h}$

at point B, $h = \frac{\omega^2 r^2}{2g}$, So $R = \frac{g}{\omega^2}$



For apparent depth.

$$\frac{n_2}{v} - \frac{n_1}{4} = \frac{n_2 - n_1}{R}$$

$$n_2 = 1, n_1 = \frac{4}{3}$$

$$u = -(H-h)$$

$$\frac{1}{V} + \frac{\frac{4}{3}}{H-h} = \frac{1 - \frac{4}{3}}{R}$$

$$\frac{1}{V} + \frac{4}{3(H-h)} = -\frac{1}{3R}$$

as $H \gg h$

$$\frac{1}{V} = -\frac{4}{3H} - \frac{\omega^2}{3g}$$

$$\left| \frac{1}{V} \right| = \frac{4}{3H} + \frac{\omega^2}{3g}$$

$$\left| \frac{1}{V} \right| = \frac{4}{3H} \left[1 + \frac{\omega^2}{3g} \times \frac{3H}{4} \right]$$

$$\left| \frac{1}{V} \right| = \frac{4}{3H} \left[1 + \frac{\omega^2 H}{4g} \right]$$

$$|V| = \frac{3H}{4} \left[1 + \frac{\omega^2 H}{4g} \right]^{-1}$$

So apparent depth is $\frac{3H}{4} \left[1 + \frac{\omega^2 H}{4g} \right]^{-1}$.



8. A student skates up a ramp that makes an angle 30° with the horizontal. He/she starts (as shown in the figure) at the bottom of the ramp with speed v_0 and wants to turn around over a semicircular path xyz of radius R during which he/she reaches a maximum height h (at point y) from the ground as shown in the figure. Assume that the energy loss is negligible and the force required for this turn at the highest point is provided by his/her weight only. Then (g is the acceleration due to gravity)

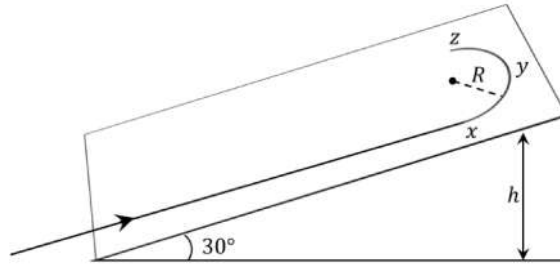

(A) $v_0^2 - 2gh = \frac{1}{2}gR$

(B) $v_0^2 - 2gh = \frac{\sqrt{3}}{2}gR$

(C) the centripetal force required at points x and z is zero

(D) the centripetal force required is maximum at points x and z

Ans. A, D

Sol. At point y centripetal force is provided by weight only

Let V_y be the speed at point y .

m be the mass of student

$$mg \sin 30^\circ = \frac{mv_y^2}{R}$$

$$v_y^2 = \frac{Rg}{2} \quad \dots (i)$$

Mechanical energy conservation between bottom and point y

$$k_i + U_i = k_f + U_f$$

$$\frac{1}{2}mv_0^2 + 0 = \frac{1}{2}mv_y^2 + mgh$$

$$v_0^2 - 2gh = V_y^2 + mgh \quad \dots (ii)$$



from equation (i) & (ii)

$$v_0^2 - 2gh = \frac{gR}{2}$$

On circular path xyz speed is maximum at x & z so centripetal force is also maximum.

9. A rod of mass m and length L , pivoted at one of its ends, is hanging vertically. A bullet of the same mass moving at speed v strikes the rod horizontally at a distance x from its pivoted end and gets embedded in it. The combined system now rotates with angular speed ω about the pivot. The maximum angular speed ω_M is achieved for $x = x_M$. Then

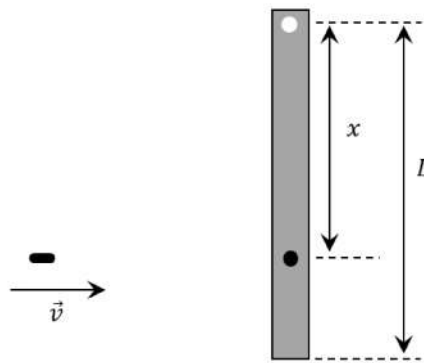

(A) $\omega = \frac{3vx}{L^2 + 3x^2}$

(B) $\omega = \frac{12vx}{L^2 + 12x^2}$

(C) $x_M = \frac{L}{\sqrt{3}}$

(D) $\omega_M = \frac{v}{2L} \sqrt{3}$

Ans. A, C, D

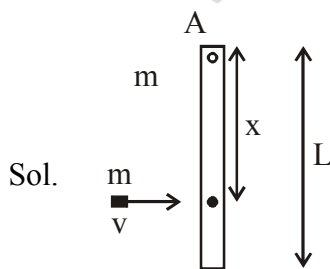

Angular momentum conservation about point A

$$L_i = L_f$$

$$mvx = \frac{mL^2}{3} \omega + mx^2 \omega$$



$$\omega = \frac{3vx}{L^2 + 3x^2}$$

For maximum angular speed

$$\frac{d\omega}{dx} = \frac{(L^2 + 3x^2)(3v) - 3vx(6x)}{(L^2 + 3x^2)^2} = 0$$

$$3vL^2 + 9vx^2 - 18vx^2 = 0$$

$$9x^2 = 3L^2$$

$$x = \frac{L}{\sqrt{3}}$$

$$\omega_m = \frac{3V \times \frac{L}{\sqrt{3}}}{L^2 + \frac{3L^2}{3}}$$

$$\omega_M = \frac{v}{2L} \sqrt{3}$$

10. In an X-ray tube, electrons emitted from a filament (cathode) carrying current I hit a target (anode) at a distance d from the cathode. The target is kept at a potential V higher than the cathode resulting in emission of continuous and characteristic X-rays. If the filament current I is decreased to $\frac{I}{2}$, the potential difference V is increased to $2V$, and the separation distance d is reduced to $\frac{d}{2}$, then
- (A) the cut-off wavelength will reduce to half, and the wavelengths of the characteristic X-rays will remain the same
- (B) the cut-off wavelength as well as the wavelengths of the characteristic X-rays will remain the same
- (C) the cut-off wavelength will reduce to half, and the intensities of all the X-rays will decrease
- (D) the cut-off wavelength will become two times larger, and the intensity of all the X-rays will decrease

Ans. A, C



Sol.

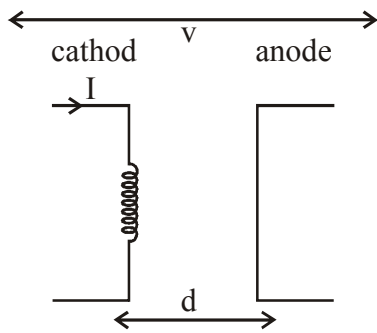

Initially maximum kinetic energy

$$eV = \frac{hc}{(\lambda \min)_1}$$

Finally maximum kinetic energy (as potential difference is doubled)

$$2eV = \frac{hc}{(\lambda \min)_2}$$

$$(\lambda \min)_2 = \frac{(\lambda \min)_1}{2}$$

As filament current is halved so number of electrons emitted will be halved so intensity of all X-Ray will decrease.

11. Two identical non-conducting solid spheres of same mass and charge are suspended in air from a common point by two non-conducting, massless strings of same length. At equilibrium, the angle between the strings is α . The spheres are now immersed in a dielectric liquid of density 800 kg m^{-3} and dielectric constant 21. If the angle between the strings remains the same after the immersion, then
- (A) electric force between the spheres remains unchanged
 - (B) electric force between the spheres reduces
 - (C) mass density of the spheres is 840 kg m^{-3}
 - (D) the tension in the strings holding the spheres remains unchanged

Ans. A, C



Sol. In - air

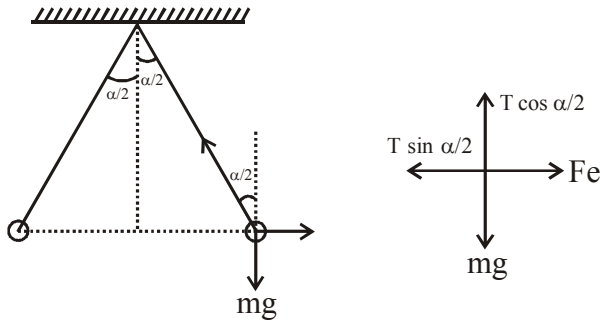

m = mass of sphere

Fe = electric force between spheres.

$$T \sin \frac{\alpha}{2} = F_e \quad \dots\dots\dots (i)$$

$$T \cos \frac{\alpha}{2} = mg \quad \dots\dots\dots (ii)$$

from (i) and (ii)

$$\tan \frac{\alpha}{2} = \frac{F_e}{mg} \quad \dots\dots\dots (iii)$$

In liquid

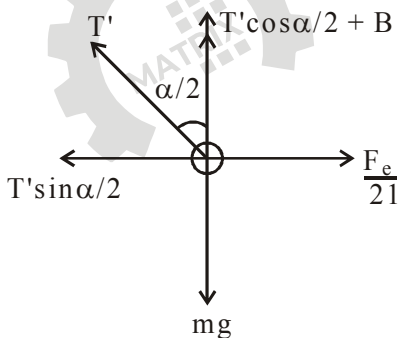

$$T' \cos \frac{\alpha}{2} + B = mg$$

$$T' \cos \frac{\alpha}{2} = mg - B \quad \{B = \text{Buoyant force}\}$$

$$T' \cos \frac{\alpha}{2} = mg - B \quad \dots\dots\dots (iv) \quad \{V = \text{volume of sphere}\}$$



$$T \sin \frac{\alpha}{2} = \frac{Fe}{21} \quad \dots\dots\dots (v)$$

$$\text{from (iv) \&(v) } \tan \frac{\alpha}{2} = \frac{Fe}{21(mg - B)} \quad \dots\dots\dots(vi)$$

from (iii) & (vi)

$$21 (mg - B) = mg$$

$$20 mg = 21B$$

$$20 \rho_m vg = 21 \rho_l vg$$

$$20 \rho_m V_g = 21 \rho_l V_g$$

$$\rho_m = \frac{21 \rho_l}{20} = 840 \text{ kg/m}^3$$

electric force between two charges does not depend on medium.

- 12.** Starting at time $t = 0$ from the origin with speed 1 ms^{-1} , a particle follows a two-dimensional trajectory in the x - y plane so that its coordinates are related by the equation $y = \frac{x^2}{2}$. The x and y components of its acceleration are denoted by a_x and a_y , respectively. Then
- (A) $a_x = 1 \text{ ms}^{-2}$ implies that when the particle is at the origin, $a_y = 1 \text{ ms}^{-2}$
 - (B) $a_x = 0$ implies $a_y = 1 \text{ ms}^{-2}$ at all times
 - (C) at $t = 0$, the particle's velocity points in the x -direction
 - (D) $a_x = 0$ implies that at $t = 1 \text{ s}$, the angle between the particle's velocity and the x axis is 45°

Ans B, C, D

Sol. $y = \frac{x^2}{2}$

differentiate wrt t on both the sides

$$\frac{dy}{dt} = x \frac{dx}{dt}$$

$$V_y = x V_x$$

differentiate wrt t on both the sides

$$\frac{dV_y}{dt} = \left(\frac{dx}{dt} \right) V_x + x \frac{d^2V_x}{dt^2}$$

$$a_y = V_x^2 + x a_x \quad \dots\dots\dots(i)$$

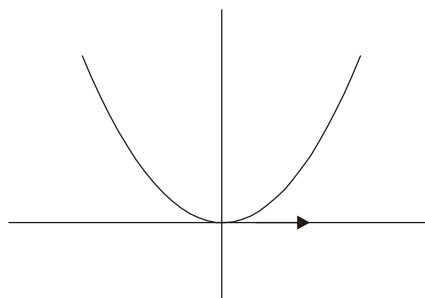



V_x = component of velocity in x-direction

V_y = component of velocity in y-direction

(A) at origin, velocity is along x-Axis so

$$V_x = 1 \text{ m/s}, V_y = 0$$

So, at origin for any value of $a_x, a_y = 1$

Hence it is incorrect

(B) if $a_x = 0$, means velocity in x-direction is constant $V_x = 1 \text{ m/s}$.

So, $a_y = 1 \text{ m/s}^2$ (from equation (i))

(C) tangent to path at origin, is along x-Axis

So at $t = 0$, velocity is in x-direction

(D) $a_x = 0, v_x = 1 \text{ m/s}$, (at any time)

$$a_y = 1 \text{ m/s}^2, V_y = 0, V_y = a_y t$$

initial $V_y = 1 \text{ m/s}$ (at $t = 1$)

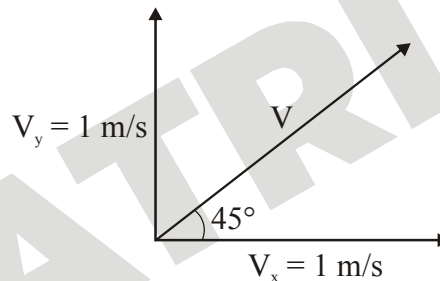

SECTION-3 (Maximum Marks : 24)

- * This section contains SIX (06) questions. The answer to each question is a NUMERICAL VALUE.
- * For each question, enter the correct numerical value of the answer using the mouse and the on-screen virtual numeric keypad in the place designated to enter the answer. If the numerical value has more than two decimal places truncate/round-off the value to TWO decimal placed.

* Answer to each question will be evaluated according to the following marking scheme :

Full Marks : +4 If ONLY the correct numerical value is entered.

Zero Marks : 0 In all other cases.

13. A spherical bubble inside water has radius R . Take the pressure inside the bubble and the water pressure to be p_0 . The bubble now gets compressed radially in an adiabatic manner so that its radius becomes $(R - a)$. For $a \ll R$ the magnitude of the work done in the process is given by $(4\pi p_0 R a^2)X$, where X is a constant and $\gamma = C_p/C_v = 41/30$. The value of X is _____.

Ans. 1



Sol. Initially $V_1 = \frac{4}{3}\pi R^3$

$$P_1 = P_0$$

finally $V_2 = \frac{4}{3}\pi (R-a)^3$

Bi-nomial approximation

$$V_2 = \frac{4}{3}\pi R^3 \left(1 - \frac{3a}{R}\right)$$

$$V_2 = V_1 \left(\frac{1-3a}{R}\right)$$

adiabatic process $P_1 V_1^\gamma = P_2 V_2^\gamma$

$$P_0 V_1^\gamma = P_2 V_1^\gamma \left(1 - \frac{3a}{R}\right)^\gamma$$

$$P_2 = P_0 \left(1 - \frac{3a}{R}\right)^{-\gamma}$$

Bi-nomial approximation

$$P_2 = P_0 \left(1 + \gamma \frac{3a}{R}\right)$$

$$P_2 = P_0 \left(1 + \frac{41}{30} \times \frac{3a}{R}\right)$$

$$P_2 = P_0 \left(1 + \frac{41a}{10R}\right)$$

Work done $W = \frac{P_1 V_1 - P_2 V_2}{\gamma - 1}$

$$= \frac{P_0 V_1 - P_0 \left(1 + \frac{41a}{10R}\right) V_1 \left(1 - \frac{3a}{R}\right)}{\gamma - 1}$$

$$= \frac{P_0 V_1}{\gamma - 1} \left[1 - \left(1 + \frac{41a}{10R}\right) \left(1 - \frac{3a}{R}\right) \right] \text{ (Bi-nomial approximation)}$$



$$= \frac{P_0 \times \frac{4}{3} \pi R^3}{\left(\frac{11}{30}\right)} \left[\frac{3a}{R} - \frac{41a}{10R} + \frac{123a^2}{10R^2} \right]$$

$$= \frac{40}{11} P_0 \pi R^3 \left[\frac{3a}{R} - \frac{41a}{10R} + \frac{123a^2}{10R^2} \right] \quad \left(\frac{a^2}{R^2} \approx 0 \right) \text{ (as } a \ll R)$$

$$= \frac{40}{11} P_0 \pi R^3 \frac{(-11)a}{10R}$$

$$\text{work done} = -4\pi P_0 R^2 a$$

$$\text{magnitude of work done} = 4\pi P_0 R^2 a$$

14. In the balanced condition, the values of the resistances of the four arms of a Wheatstone bridge are shown in the figure below. The resistance R_3 has temperature coefficient $0.0004 \text{ } ^\circ\text{C}^{-1}$. If the temperature of R_3 is increased by $100 \text{ } ^\circ\text{C}$, the voltage developed between S and T will be _____ volt.

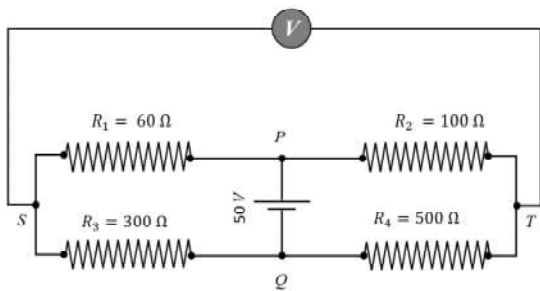

Ans 0.27

Sol. After temperature increase R_3 becomes $300 (1 + 0.0004 \times 100) = 312 \text{ } \Omega$

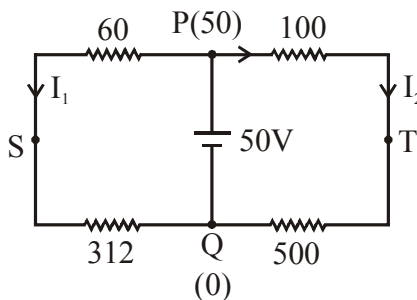

$$I_1 = \frac{50}{372}$$

$$\therefore \text{Potential } V_s = 312 \times I$$



$$= \frac{312}{372} \times 50$$

$$= 41.94$$

$$I_2 = \frac{50}{600}$$

$$\therefore \text{Potential } V_T = 500 \times \frac{50}{600} = 41.67$$

$$\text{Potential difference } \Delta V = V_s - V_T$$

$$= 0.27\text{V}$$

15. Two capacitors with capacitance values $C_1 = 2000 \pm 10$ pF and $C_2 = 3000 \pm 15$ pF are connected in series. The voltage applied across this combination is $V = 5.00 \pm 0.02$ V. The percentage error in the calculation of the energy stored in this combination of capacitors is _____.

Ans 1.3

Sol. $\frac{1}{c} = \frac{1}{c_1} + \frac{1}{c_2} \Rightarrow c = \frac{2000 \times 3000}{5000} = 1200 \text{ PF}$

$$-\frac{dc}{c^2} = -\frac{dc_1}{c_1^2} - \frac{dc_2}{c_2^2} \Rightarrow \frac{dc}{(1200)^2} = \frac{10}{(2000)^2} + \frac{15}{(3000)^2}$$

$$\Rightarrow dc = (12)^2 \left[\frac{1}{40} + \frac{1}{60} \right]$$

$$= (12)^2 \left[\frac{3+2}{10} \right] = \frac{12 \times 5}{10} = 6$$

$$\therefore c = 1200 \pm 6 \text{ PF}$$

$$\text{and } U = \frac{1}{2} c V^2$$

$$\Rightarrow \frac{dU}{U} = \frac{dc}{c} + \frac{2dv}{v} = \left[\frac{6}{1200} + \frac{2 \times 0.02}{5} \right]$$

$$\Rightarrow \frac{dU}{U} \times 100\% = \left[\frac{1}{2} + \frac{4}{5} \right] \% = 1.3\%$$



16. A cubical solid aluminium (bulk modulus = $-V \frac{dP}{dV} = 70 \text{ GPa}$) block has an edge length of 1 m on the surface of the earth. It is kept on the floor of a 5 km deep ocean. Taking the average density of water and the acceleration due to gravity to be 10^3 kg m^{-3} and 10 ms^{-2} , respectively, the change in the edge length of the block in mm is _____.

Ans 0.24

Sol. Excess pressure at floor of ocean (Δp) = $\rho gh = 5 \times 10^7 \text{ pa}$

$$\therefore v = l^3$$

$$\Rightarrow dv = 3l^2 dl$$

$$\frac{dv}{v} = \frac{3dl}{l} \dots\dots\dots(1)$$

$$\Rightarrow \frac{-\Delta p}{(dv/v)} = 70 \times 10^9$$

$$\Rightarrow \frac{5 \times 10^7}{3 \left(\frac{dl}{l} \right)} = 70 \times 10^9$$

$$\frac{dl}{l} = \frac{5}{21} \times 10^{-3} \text{ m}$$

$$\Rightarrow dl = \frac{5}{21} \times 10^{-3} \text{ m} = \frac{5}{21} \text{ mm}$$

$$= 0.24 \text{ mm}$$



17. The inductors of two LR circuits are placed next to each other, as shown in the figure. The values of the self-inductance of the inductors, resistances, mutual-inductance and applied voltages are specified in the given circuit. After both the switches are closed simultaneously, the total work done by the batteries against the induced EMF in the inductors by the time the currents reach their steady state values is _____ mJ.

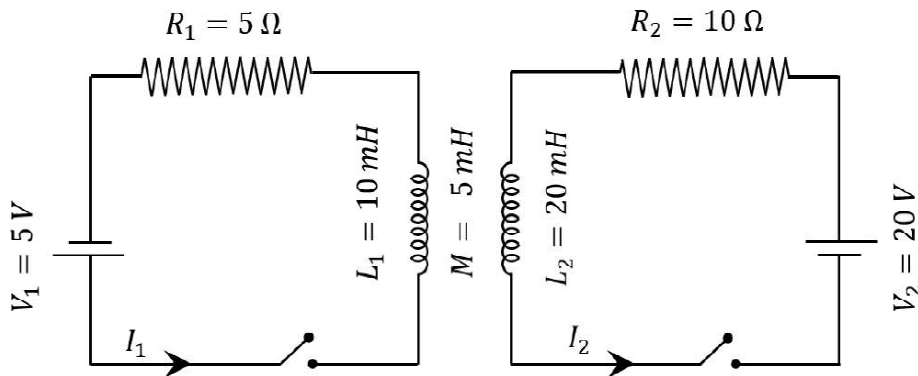

Ans 55

Sol.

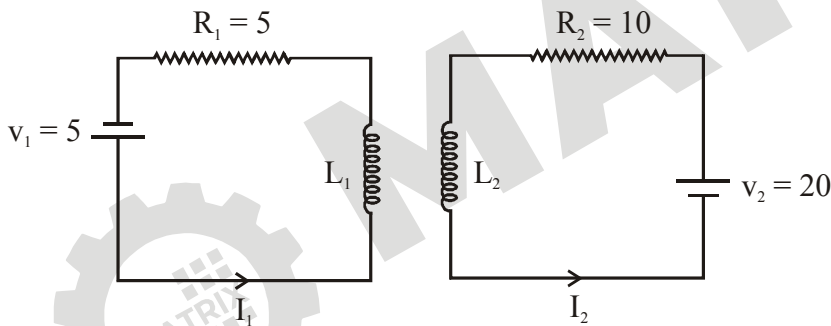

$$\text{In steady state } I_1 = \frac{5}{5} = 1 \text{ A} \text{ \& } I_2 = \frac{20}{10} = 2 \text{ A}$$

$$E_{1\text{ind}} \text{ (in } L_1)$$

$$E_{1\text{ind}} = \frac{L_1 dI_1}{dt} + \frac{MdI_2}{dt}$$

$$E_{2\text{ind}} = \frac{L_2 dI_2}{dt} + \frac{MdI_1}{dt}$$

$$dw_1 = E_1 I_1 dt = L_1 I_1 dI_1 + M I_1 dI_2$$

$$dw_2 = E_2 I_2 dt = L_2 I_2 dI_2 + M I_2 dI_1$$

$$dw = dw_1 + dw_2 = L_1 I_1 dI_1 + L_2 I_2 dI_2 + Md(I_1 I_2)$$



$$\therefore w = \frac{L_1 I_1^2}{2} + \frac{L_2 I_2^2}{2} + M I_1 I_2 = 55 \text{ mJ}$$

18. A container with 1 kg of water in it is kept in sunlight, which causes the water to get warmer than the surroundings. The average energy per unit time per unit area received due to the sunlight is 700 Wm^{-2} and it is absorbed by the water over an effective area of 0.05 m^2 . Assuming that the heat loss from the water to the surroundings is governed by Newton's law of cooling, the difference (in $^\circ\text{C}$) in the temperature of water and the surroundings after a long time will be _____. (Ignore effect of the container, and take constant for Newton's law of cooling = 0.001 s^{-1} , Heat capacity of water = $4200 \text{ J kg}^{-1} \text{ K}^{-1}$).

Ans 8.33

Sol. I (sunlight) = 700 w/m^2

$$\text{Area } A = 0.05 \text{ m}^2$$

$$\therefore P_{\text{received}} = IA = 35 \text{ J/S}$$

After long time rate of heat absorption = rate of emission

From newtons law of cooling

$$\frac{dT}{dt} = -k(\Delta T)$$

$$\Rightarrow \frac{dT}{dt} = -0.001(\Delta T)$$

$$\because P_{\text{loss}} = P_{\text{received}}$$

$$\Rightarrow -ms \frac{dT}{dt} = 35$$

$$\Rightarrow 1 \times 4200 \times 0.001 \times \Delta T = 35$$

$$\Rightarrow \Delta T = 8.33 \text{ }^\circ\text{C}$$